

Universal V™ In-Line Water Cut Meter

with Spool Piece Mounting

Use the Best

For over 50 years, Drexelbrook has been the world's leader in capacitive-based measurements by providing reliable and accurate products at a reasonable cost. We offer the highest pressure and temperature ratings in the industry, 1000 PSI and temperatures up to 450 °F.

Easy Configuration with Built-in Display and Keypad

All Universal V CM comes from the factory pre-calibrated and requires only one point validation. Field configuration can be done from anywhere along the two-wire loop with our HRTWin PC Software. You can also configure via local display / keypad without the need for laptop or handheld communicators.

Worldwide Approvals

The Universal V CM Model has been approved for Class I, Div1 hazardous locations. FM and FMc, ATEX and IECEx approvals are available.

Eliminate Routine Maintenance

The Universal V CM ignores paraffin and other coatings that buildup on the probe. No need to take apart the spool pieces and tie-off large pipelines. The Universal V CM can be configured as either an insertion probe with a NPT fitting (Reference our Universal V CM Model with Temperature compensation datasheet (UVCMT-A)) or as a flanged mounted in-line spool probe for most common pipe diameters.

Temperature Compensation

The dielectric constant of crude oil can change with any changes in temperature. These changes may cause standard cut monitors to change without any variance in water content. The Universal V Water Cut Monitor measures product temperature internally and calculates a true water cut reading at any temperature within the process temperature range.

APPLICATIONS

- Automatic Well Testing (AWT)
- Lease Automatic Custody Transfer (LACT)
- Basic Sediment and Water (BS&W)
- Separation Vessels
- Truck Unloading
- Pump Protection
- Dielectric Analysis
- Machinery Lube Oil Monitoring

3-YEAR WARRANTY



Universal V™ In-Line Water Cut Meter

Operating Principle

The method of using RF Admittance to measure water cut is widely successful because of the large difference between the dielectric constants of oil ($k \approx 2.3$) and water ($k \approx 80$). The sensing element and the pipe wall form the necessary two surfaces of the concentric capacitor. The system electronics transmit a radio frequency voltage to the sensing element that measures changes in capacitance. As the amount of water in the flowing oil increases, the net dielectric of the fluid increases which causes the capacitance to increase. The addition of temperature compensation allows the user to take into account changes in the dielectric constant of the oil producing a more accurate measurement in applications where the temperature changes. The onboard electronics will compute the relationship between capacitance change and water cut. Straightforward, Reliable, Proven.

Typical Arrangement

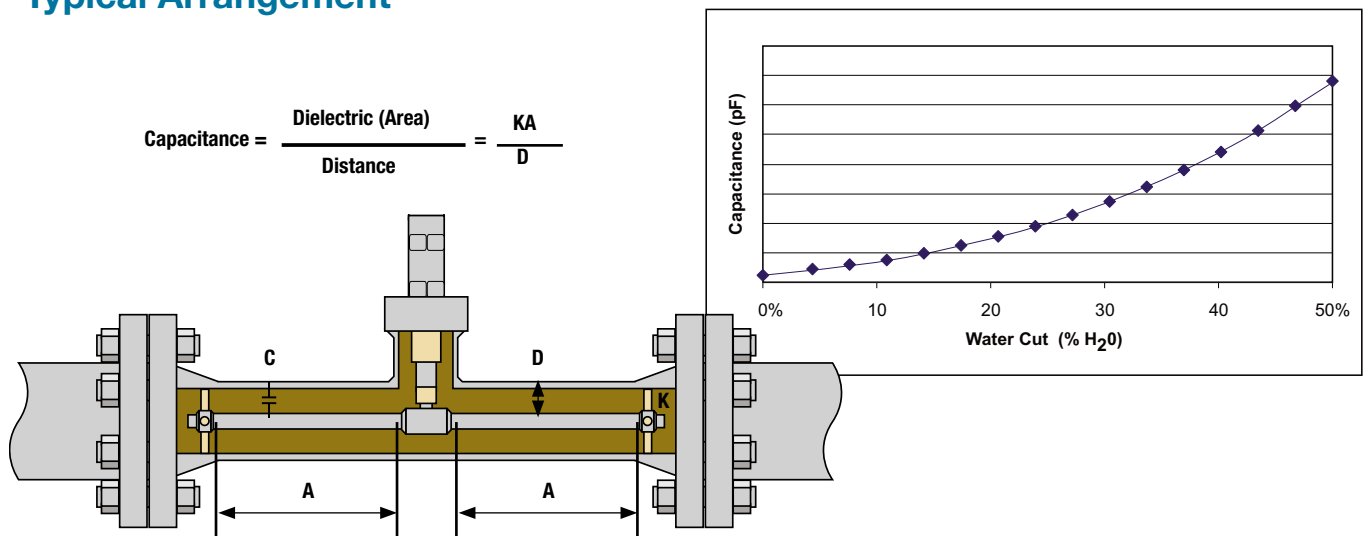

Drexelbrook Sampling Advantage

The Drexelbrook In-Line probe design enables it to analyze a large representative sample of the fluid that other manufacturers can not. The Universal V CM utilizes a industry standard size sensing element that can be installed directly into the process piping. The sensing element shown will extend directly into the main process line. The advantage of this is the capacitance of the fluid is taken over the entire length of the probe to create an averaging effect. The measurement is now taking a better sample of the fluid over a larger range to produce a smoother, more accurate, response.

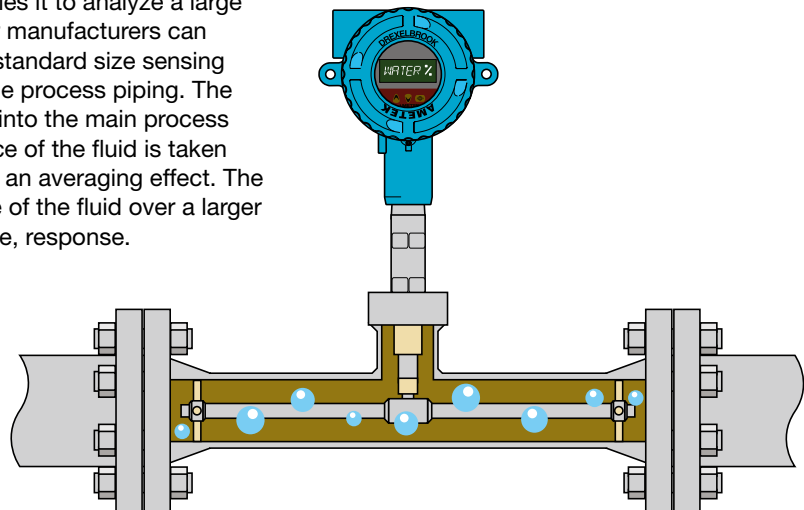

Universal V™ In-Line Water Cut Meter

Specifications

Technology

RF Admittance / Capacitance

Supply Voltage

16-30 VDC, 2-wire loop powered

Output/Digital Protocol

4-20mA, HART

Compatible with HART®

Accuracy and Resolution – Standard Electronics

Water Cut Range	Nominal Water Cut Variance*	Water Cut Resolution**
0 to 1%	+/- 0.03	0.0002
0 to 5%	+/- 0.04	0.0009
0 to 10%	+/- 0.04	0.0009
0 to 30%	+/- 0.12	0.0030
0 to 50%	+/- 0.35	0.0080
0 to 80% (Heavy Oil)	+/- 0.25	0.0035

Accuracy and Resolution – Temperature Compensation

Water Cut Range	Nominal Water Cut Variance*	Water Cut Resolution**
0 to 1%	+/- 0.03	0.0002
0 to 5%	+/- 0.04	0.0009
0 to 10%	+/- 0.04	0.0009
0 to 30%	+/- 0.12	0.0030

Above 30% - Consult Factory

* The measurement accuracy of an inline, dynamic water cut measurement is dependent upon many process variables including: oil dielectric consistency, fluid velocity at the sample point, mounting geometry and homogeneity of the oil/water emulsion. The values above represent nominal water cut measurement variances for a properly installed sensor under consistent measurement point conditions.

** The smallest water cut step that the instrument can resolve

Load Resistance

363 Ohms @ 24 VDC

636 Ohms @ 30 VDC

Minimum 250 Ohms for HART Communications

Ambient Temperature

-40 to 75 °C (-40 to 167 °F)

Process Temperature

Up 232 °C (450 °F)

Process Pressure

Up 69 bar (1,000 psi), probe dependent

Process Connection

2", 3", and 4" Spool Options

Response Time

350 msec nominal (no damping applied)

1-90 seconds programmable damping time

Supply Voltage Effect

0.2% of full scale max

Process Temperature (Compensated)

Up 232 °C (450 °F) – Transmitter will compensate for the effects of temperature when the water is in liquid state (e.g., 0 °C to 100 °C at ambient pressure)

Start-Up Time

< 12 seconds

Configuration and Calibration

Standard LCD display and keypad are built-in

HRTWIN™ PC-based software (free download)

Emission and Surge Protection

Compliant with IEC6100-4.2, 3, 4, 6, 8

Compliant with CISPR11 Group I, Class B

Approvals

Intrinsically Safe (IS)

Explosion Proof (XP)

FM, FMc

ATEX, IECEx



Universal V™ In-Line Water Cut Meter

Mounting / Dimensions

The Cut Monitor sensing element varies with pipe size. The larger the pipe diameter size, the longer the sensing element active length must be. The Cote-Shield length is sized so the sensing element is fully extended into the fluid beyond nozzles and elbows. Below are some standard look up tables.

Size	Dimension "A"	Dimension "B"	Dimension "C"	Dimension "D"	Flange
2 inch	17.0" (432)	13.4" (340)	8.5" (216)	2.125" (54)	150#/300#
3 inch	32.0" (813)	13.9" (353)	19.0" (429) *Not in Center	3.125" (79)	150#/300#
4 inch	32.0" (813)	14.3" (363)	21.8" (554) *Not in Center	4.625"(117)	150#/300#

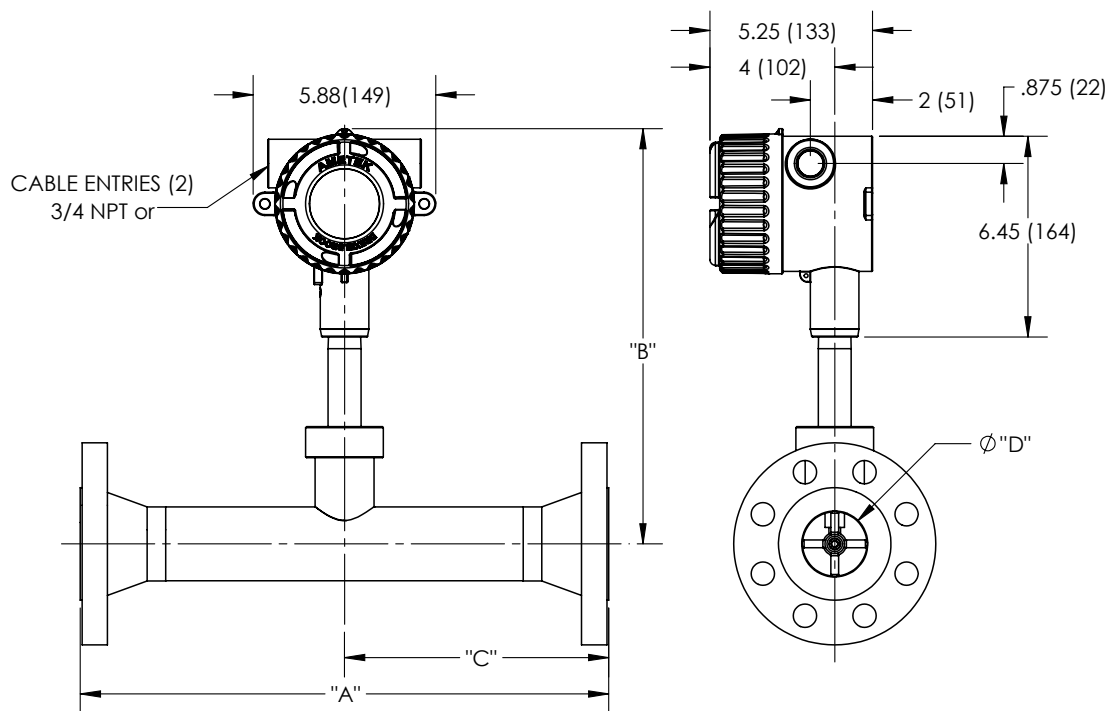

Universal V™ In-Line Water Cut Meter

Model Numbering - System Electronics and Probe Model

Technology

V Universal V

Measurement Type / Frequency and Phasing

CO Water Cut Monitor

TO Water Cut Monitor with Temperature Compensation Electronics

Digital Protocols

1 HART®

Future Use

0 Future Use

Approvals

0 Unapproved	4 ATEX d
1 FM/FMc IS	5 IECEx ia
2 FM/FMc XP	6 IECEx d
3 ATEX ia	

Electrical Connection

0 3/4" NPT without external ground lug
1 M20 with external ground Equipotential Bonding
2 3/4 with external ground Equipotential Bonding

Surge / Noise Suppression

0 No additional filtering required
1 Signal RFI (Integral)

Integral / Remote options

0 Integral configuration	E Remote configuration with 10 ft Hi Temp Cable
1 Remote configuration without cable	F Remote configuration with 25 ft. Hi Temp Cable
2 Remote configuration with 10 ft General Purpose Cable	L Remote configuration with 10 ft Hi Temp Composite Cable
3 Remote configuration with 25 ft. General Purpose Cable	M Remote configuration with 25 ft. Hi Temp Composite Cable
8 Remote configuration with 10 ft. Triax Cable	Z Remote configuration with custom cable
9 Remote configuration with 25 ft. Triax Cable	

Dual seal option

0 Without Dual Seal option
1 Dual Seal

Sensing Element Code

S02 700-1230-002-XX 2" Spool

S03 700-1230-003-XX 3" Spool

S04 700-1230-004-XX 4" Spool

S12 700-1230-102-XX 2" Spool (Integral Only, No Dual Seal)

S13 700-1230-103-XX 3" Spool (Integral Only, No Dual Seal)

S14 700-1230-104-XX 4" Spool (Integral Only, No Dual Seal)

S42 700-1230-402-XX 2" Spool with Temperature Compensation (Integral Only, No Dual Seal)

S43 700-1230-403-XX 3" Spool with Temperature Compensation (Integral Only, No Dual Seal)

S44 700-1230-404-XX 4" Spool with Temperature Compensation (Integral Only, No Dual Seal)

Cut Monitor Software

0 None	F Heavy Oil -- 0 - 1%
A Light Oil -- 0 - 1%	G Heavy Oil -- 0 - 5%
B Light Oil -- 0 - 5%	H Heavy Oil -- 0 - 10%
C Light Oil -- 0 - 10%	I Heavy Oil -- 0 - 30%
D Light Oil -- 0 - 30%	J Heavy Oil -- 0 - 50%
E Light Oil -- 0 - 50%	M Heavy Oil -- 0 - 80%
	Z Special Software

Model Numbering Example: V XX 1 0 X X X 0 0 SXX X

NOTE: Temperature Compensation electronics limited to 30% water cut

Universal V™ In-Line Water Cut Meter

Model Numbering - Probe Dimensions and Process Connection

Probe Type													
700	-	1230	Spool Piece Probe										
			Pipe Size										
			0	0	2	2 Inch I.D.X 17" Face to Face							
			0	0	3	3 Inch I.D.X 32" Face to Face							
			0	0	4	4 Inch I.D.X 32" Face to Face							
			1	0	2	2 Inch I.D.X 17" Face to Face							
			1	0	3	3 Inch I.D.X 32" Face to Face, Integral, No Dual Seal							
			1	0	4	4 Inch I.D.X 32" Face to Face, Integral, No Dual Seal							
			4	0	2	2 Inch I.D.X 17" Face to Face, Integral With Temp. Comp., No Dual Seal							
			4	0	3	3 Inch I.D.X 32" Face to Face, Integral With Temp. Comp., No Dual Seal							
			4	0	4	4 Inch I.D.X 32" Face v Face, Integral With Temp. Comp., No Dual Seal							
			Material Type										
			0	1	Carbon Steel								
			0	4	316 Stainless Steel								
						Flange Type							
			0	1	5	150 lb. ANSI Raised Face Weld Neck; Schedule 40 Pipe							
			0	1	6	150 lb. ANSI RTJ Weld Neck; Schedule 40 Pipe							
			0	3	0	300 lb. ANSI Raised Face Weld Neck; Schedule 40 Pipe							
			0	3	1	300 lb. ANSI RTJ Weld Neck; Schedule 40 Pipe							
700	-	1230	-	X	X	X	-	X	X	-	X	X	X

How To Order

To order a Universal V CM, users must specify the following items:

1. Percentage of Water-In-Oil
2. Approvals Required
3. Integral or Remote Electronics with Cable Length
4. Pipe Size
5. Installation Services
6. Cut Monitor Accessories
7. Pressure & Temperature of Process
8. API Gravity

The model numbering maps show how to place your specifications into our part numbering system. There are two model maps, one for the electronics and one for the probe. Please provide both numbers when ordering.

DREXELBROOK® / **AMETEK®**
An ISO 9001 Certified Company **LEVEL MEASUREMENT SOLUTIONS**

205 Keith Valley Road, Horsham, PA 19044
Telephone: 215-674-1234
E-mail: drexelbrook.info@ametek.com
ametek-measurement.com

AMETEK LMS Bulletin 64-104.3
Effective: June 2024