



## DR7100 Supplementary instructions

Guided Radar (TDR) Level Meter for 2-wire control systems

Supplementary Instructions for PROFIBUS PA communication



1	General safety information	3
1.1	Scope of the document	3
1.2	Device description	3
1.3	Scope of delivery	3
2	PROFIBUS PA data	4
3	Electrical connections	5
3.1	Electrical installation: terminals	5
3.2	Electrical connection: PACTware™	6
4	Operation	7
4.1	Description of device data	7
4.1.1	General information	7
4.1.2	Measurement data	7
4.1.3	Status data	8
4.2	PROFIBUS PA address	9
4.2.1	Default address	9
4.2.2	How to change the address	9
4.3	Error handling	9
5	Notes	10

## 1.1 Scope of the document

These instructions are applicable only to the TDR level transmitter with the PROFIBUS PA communication option. For all other data, use the Quick Start and other chapters of the Handbook. If you do not have these documents, please contact the nearest office or download them from the manufacturer's internet site.



### **INFORMATION!**

*The information in this chapter only contains the data applicable to PROFIBUS PA communication. The technical data in the Handbook shall be valid in its current version, provided that it is not rendered invalid or replaced by this supplement.*

## 1.2 Device description

This device is a 4-wire level transmitter that uses TDR (Time Domain Reflectometry) / Guided Radar technology. The device measures the level, distance, volume and mass of liquids, liquid gases, pastes, powders, slurries and granular products. It is also suitable for the continuous and simultaneous measurement of level and interface of 2 liquids. Measurements are displayed via a DTM (device type manager) for remote communication or an optional integrated display screen with wizard-driven setup and online help functions.

The level transmitter is approved for use in potentially explosive atmospheres when equipped with the appropriate options.

## 1.3 Scope of delivery

The information in this chapter only contains the data applicable to PROFIBUS PA communication. The technical data in the Handbook shall be valid in its current version, provided that it is not rendered invalid or replaced by this supplement.

A device for PROFIBUS PA communication is supplied with

- Supplementary Instructions for PROFIBUS PA communication
- PROFIBUS device data files (GSD) on a CD-ROM supplied with the device

**INFORMATION!**

- The data that follows is applicable only for fieldbus communication networks. For general data, refer to the handbook.
- Additional information (certificates, special tools, software, files...) and complete product documentation is on the CD delivered with the device or can be downloaded free of charge from the website.

Type	TDR level transmitter
Output signal	Digital signal that agrees with the PROFIBUS PA communication protocol
Profile Ident	9700

**Data blocks**

Function blocks	11 (level, distance, interface level, interface distance, layer, interface conversion, ullage conversion, layer conversion, level conversion, level mass and distance mass)
Communication Standard	PROFIBUS PA protocol that agrees with IEC 61158-2

**Physical layer**

Protocol	PROFIBUS PA protocol that agrees with IEC 61158-2, galvanically isolated
Physical layer types	Standard power signaling, bus powered, non I.S.
Other features	Bus interface with integrated reverse polarity protection

**Electrical connections**

Device power supply (24 V input)	18...30 VDC
Current consumption on PROFIBUS network	20 mA

**Input and output**

Output data	Level, distance, interface level, interface distance, layer, interface conversion, ullage conversion, layer conversion, level conversion, level mass and distance mass
Input data	None
Error current FDE	Typically 0 mA (FDE =Fault Disconnection Electronic)
Address range	0...125. Default address: 126. For more data, refer to <i>PROFIBUS PA address</i> on page 9.

### 3.1 Electrical installation: terminals

Electrical connection must agree with IEC 61158-2.

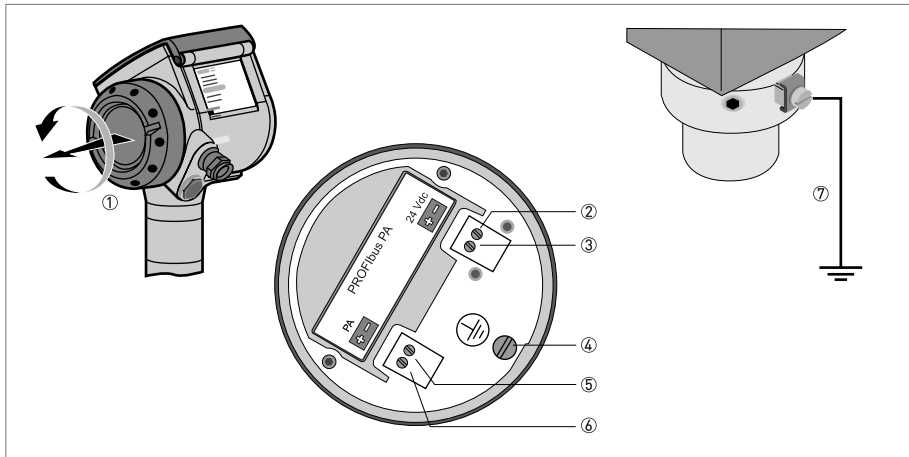

Figure 3-1: Electrical installation

- ① Terminal compartment cover
- ② Power supply terminal: 24 VDC -
- ③ Power supply terminal: 24 VDC +
- ④ Grounding terminal in the housing
- ⑤ Communication terminal: PA -
- ⑥ Communication terminal: PA +
- ⑦ Grounding terminal between the process connection and the converter



#### INFORMATION!

The PA terminal is connected to a segment coupler. The 24 VDC terminal energizes the device.



#### Procedure:

- Remove the housing terminal compartment cover ①.
- Connect the PROFIBUS PA segment to the communication terminals ⑤ and ⑥ of the device. Obey the national electrical codes and fieldbus specifications for PROFIBUS PA communication networks.
- Make sure that the polarity of the wires is correct.
- Connect the power supply to the power supply terminals ② and ③ of the device. Obey the national electrical codes.
- Make sure that the polarity of the wires is correct.
- Attach the ground to ④ or ⑦. Both terminals are technically equivalent.

### 3.2 Electrical connection: PACTware™

**CAUTION!**

Before you use PACTware™ to configure the device, disconnect the device from the PROFIBUS PA segment.

**CAUTION!**

The HART address of the device must be set to "1". If the device is not set to "1", the device will not operate in PROFIBUS PA networks. Refer to the Handbook for more data on how to change the HART address.

PACTware™ is an Open Source, open configuration software for all field devices. Use PACTware™ to configure your device. For more data, refer to "Start-up" in the handbook.

Attach a HART® converter to the terminals shown in the illustration that follows. We recommend the VIATOR converter that is available as an accessory for this device. Refer to the Handbook for more data on accessories.

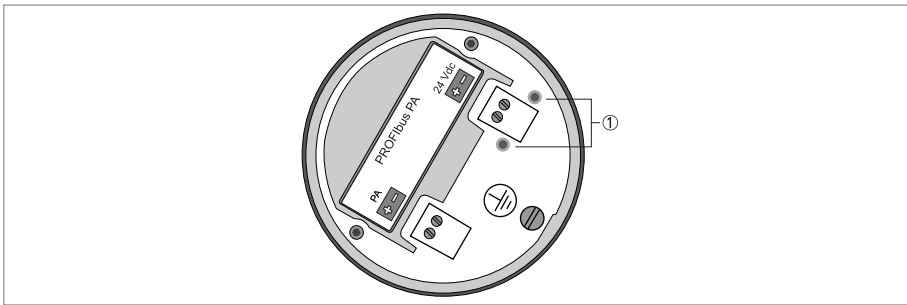

Figure 3-2: Electrical connection: PACTware™

① PACTware™ terminals

## 4.1 Description of device data

### 4.1.1 General information

Each configured measurement value is a 4-byte value with a float format that agrees with the IEEE Standard 754 Short Real Number. A status byte follows each measurement value.

### 4.1.2 Measurement data

Use a master and the GSD files to configure the device for the network. Set the measurement values (modules) that are regularly transmitted to the master device. The table that follows gives a list of measurement data (each value has a status) that is available in this sequence.

The Standard Data Format code 0x94 is used by default. If the master only operates with Extended Format code, use 0x42, 0x84, 0x08 or 0x05 as alternatives to 0x94. These codes are available in the GSD file. Approved personnel can change the format with a simple text editor.

#### Measurement data

Slot definition	Measurement variable	Unit
1	Level ①	Meter
2	Distance ①	Meter
3	Interface Level ②	Meter
4	Interface Distance ③	Meter
5	Layer ④	Meter
6	Interface Conversion ⑤	Cubic meter
7	Ullage Conversion ⑥	Cubic meter
8	Layer Conversion ⑦	Cubic meter
9	Level Conversion ⑧	Cubic meter
10	Level Mass ⑧	Ton (metric)
11	Distance Mass ⑧	Ton (metric)

- ① If the "Application Mode" value (in the device Quick Setup menu) is set to "Interface only", this measurement is not available. The message "Not\_a Number (non signalling)" is transmitted. The status is set to "Bad-Out of Service".
- ② If the "Application Mode" value (in the device Quick Setup menu) is set to "Level only", this measurement is not available. The message "Not\_a Number (non signalling)" is transmitted. The status is set to "Bad-Out of Service".
- ③ If the "Application Mode" value (in the device Quick Setup menu) is set to "Level only", this measurement is not available. The message "Not\_a Number (non signalling)" is transmitted. The status is set to "Bad-Out of Service".
- ④ If the "Application Mode" value (in the device Quick Setup menu) is set to "Level only" or "Interface only", this measurement is not available. The message "Not\_a Number (non signalling)" is transmitted. The status is set to "Bad-Out of Service".
- ⑤ If the "Application Mode" value (in the device Quick Setup menu) is set to "Level only" and there is no conversion table, this measurement is not available. The message "Not\_a Number (non signalling)" is transmitted. The status is set to "Bad-Out of Service".
- ⑥ If there is no conversion table, this measurement is not available. The message "Not\_a Number (non signalling)" is transmitted. The status is set to "Bad-Out of Service".
- ⑦ If the "Application Mode" value (in the device Quick Setup menu) is set to "Level only" or "Interface only" and there is no conversion table, this measurement is not available. The message "Not\_a Number (non signalling)" is transmitted. The status is set to "Bad-Out of Service".
- ⑧ If the "Application Mode" value (in the device Quick Setup menu) is set to "Interface only" and there is no conversion table, this measurement is not available. The message "Not\_a Number (non signalling)" is transmitted. The status is set to "Bad-Out of Service".

### 4.1.3 Status data



**CAUTION!**

Monitor the status of the device. The device transmits a measurement value when the device status is "good", "uncertain" or "bad". The status will tell you if the device measures correctly.

A measurement value has a 4-byte value and a 1-byte status. Status data is given in the table that follows:

**Status data**

Quality	Quality-Substatus	Limits	
---------	-------------------	--------	--

**General**

Gr	Gr	QS	QS	QS	QS	Qu	Qu	
$2^7$	$2^6$	$2^5$	$2^4$	$2^3$	$2^2$	$2^1$	$2^0$	
0	0							= bad
0	1							= uncertain
1	0							= good (non Cascade)

**Status = bad**

0	0	0	0	0	1			= configuration error
0	0	0	0	1	1			= device failure
0	0	0	1	0	0			= sensor failure
0	0	0	1	1	1			= out of service

**Status = uncertain**

0	1	0	0	0	1			= last usable value
0	1	0	1	1	0			= sub-normal

**Status = Good / limits**

1	0	0	0	1	0	0	0	= Good - no alarm
1	0	0	0	1	0	0	1	= Good - below low limit
1	0	0	0	1	0	1	0	= Good - above high limit
1	0	0	0	1	1	0	1	= Good - Lo-Lo
1	0	0	0	1	1	1	0	= Good - Hi-Hi
1	0	0	0	1	0	1	1	= Constant output
1	0	1	0	0	1			= maintenance required

Read the first 2 "Quality" bits in the status byte to get the quality status. A description is given in the table that follows:

Quality status	Description
Good (non Cascade)	The measurement value is correct
Uncertain	The measurement value can be used but it is possibly not accurate ①
Bad	Do not use this measurement value

① if it is possible that the value is not accurate, this status is shown

## 4.2 PROFIBUS PA address

### 4.2.1 Default address

The default slave address is 126. It is not possible to change this value in the local device menu.

### 4.2.2 How to change the address

Use a master device (a PLC or operating program) and the PROFIBUS service "SET\_SLAVE\_ADD" to change the slave address. It is not possible to change this value in the local device menu.



#### **INFORMATION!**

*If you use the PROFIBUS service "SET\_SLAVE\_ADD" to change the slave address and the "NO\_ADD\_CHG" flag has the value "true", the PROFIBUS service "SET\_SLAVE\_ADD" will not be available for subsequent changes.*



#### **If the PROFIBUS service "SET\_SLAVE\_ADD" is not available:**

- ① Use acyclic services "FACTORY\_RESET" to reset the slave address
- ② Use the PROFIBUS service "SET\_SLAVE\_ADD" to change the slave address to the new value.

## 4.3 Error handling

If the device finds an error, more data will be sent to the Master Communication Module. The description of this supplementary data is given in the GSD file. Refer to UNIT\_DIAG\_BIT(i).





AMETEK Drexelbrook makes no warranty of any kind with regard to the material contained in this manual, including, but not limited to, implied warranties or fitness for a particular purpose. Drexelbrook shall not be liable for errors contained herein or for incidental or consequential damages in connection with the performance or use of material.

© Copyright AMETEK Drexelbrook

**AMETEK**<sup>®</sup>  
DREXELBROOK

U.S. and Canada: 1-800-553-9092

24-Hour Service: 1-800-527-6297

International: +1 215-674-1234

Fax: +1 215-674-2731

E-mail: [drexelbrook.service@ametek.com](mailto:drexelbrook.service@ametek.com)

Website: [www.drexelbrook.com](http://www.drexelbrook.com)