

DREXELBROOK®

A Leader in Level Measurement

Upgrade Installation Guide

For the

Universal IV™ Lite and Universal IV™ Pro
Model Transmitters

2-Wire RF Admittance / Capacitance Level
Measurement System with HART® Protocol

For Assistance Call 1-800-527-6297
Outside North America + 215-674-1234

AMETEK®
DREXELBROOK

AMETEK Drexelbrook makes no warranty of any kind with regard to the material contained in this manual, including, but not limited to, implied warranties or fitness for a particular purpose. Drexelbrook shall not be liable for errors contained herein or for incidental or consequential damages in connection with the performance or use of material.

© Copyright AMETEK Drexelbrook

EDO# 3-12-121
UIV Upgrade-LM
Issue # 1

Universal IV™ Transmitter with HART® Protocol



AMETEK®
DREXELBROOK
An ISO 9001 Certified Company

205 Keith Valley Road, Horsham, PA 19044
U.S. and Canada: 1-800-553-9092
24-Hour Service: 1-800-527-6297
International: +1 215-674-1234
Fax: +1 215-674-2731
E-mail: drexelbrook.info@ametek.com
Website: www.drexelbrook.com

Table of Contents

Universal IV Upgrade Package - Integral.....	1
Universal IV Upgrade Package - Remote.....	4

Universal IV Upgrade Package - Integral

The Universal IV integral upgrade package includes:

- Universal IV electronics in housing
- Interconnect cable
- Heat-shrink tubing
- Extension tube (if applicable)



Note: Not all sensing elements require an extension tube.

Description	Part Number	Upgrade Kit Number										
		R00	R01	R02	R03	R04	R05	R11	R12	R13	R14	R15
Cable Assembly, 2 terminal, 5.25" long	380-9000-079	X	X					X				
Cable Assembly, 3 terminal, 11.5" long	380-9000-127	X		X		X			X		X	
Cable Assembly, 2 terminal, 11.5" long	380-9000-128	X			X		X			X		X
Extension Tube, 3/4 NPT, 5" long	242-0006-100	X		X			X		X			X
Extension Tube, 1 NPT, 8" long	242-0006-113	X			X	X				X	X	
Screw, 6-32 x 1/4", Red	220-0002-115	X		X		X			X		X	
Screw, 6-32 x 1/4", Blue	220-0002-116	X	X	X	X	X	X	X	X	X	X	X
Heat-shrink Tubing, 1" I.D. Expanded	388-0001-067	X	X	X	X	X	X	X	X	X	X	X

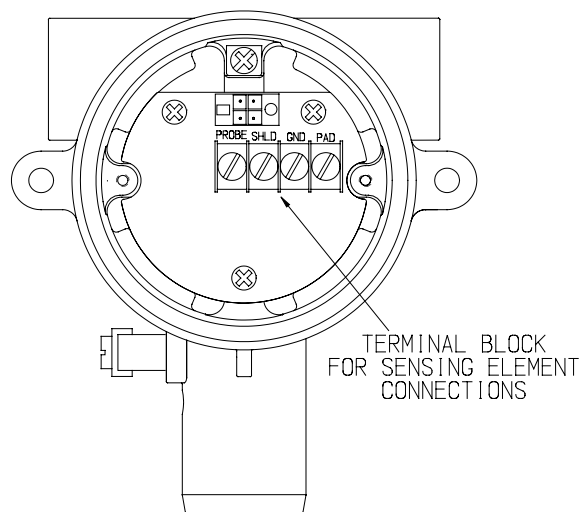
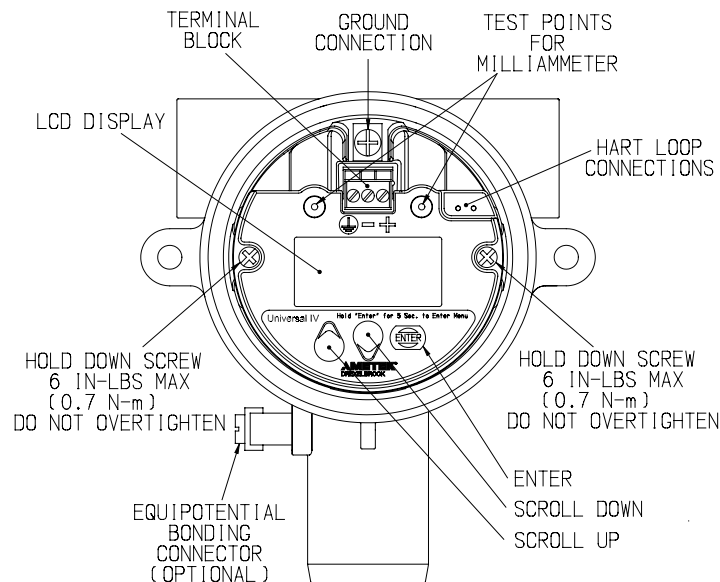

ELECTRONIC UNIT REMOVED

Preparing the system for upgrade:

1. Disconnect the loop wires from the existing system.
2. Disconnect the interconnect cable from the transmitter and the sensing element
3. Remove the spark protector from the sensing element (not installed on all systems).



Note: The spark protector will not be reinstalled; the Universal IV electronics has built-in spark protection.

4. Remove the housing from the sensing element by rotating counterclockwise.



Warning: Be careful not to loosen the packing gland on the sensing element.

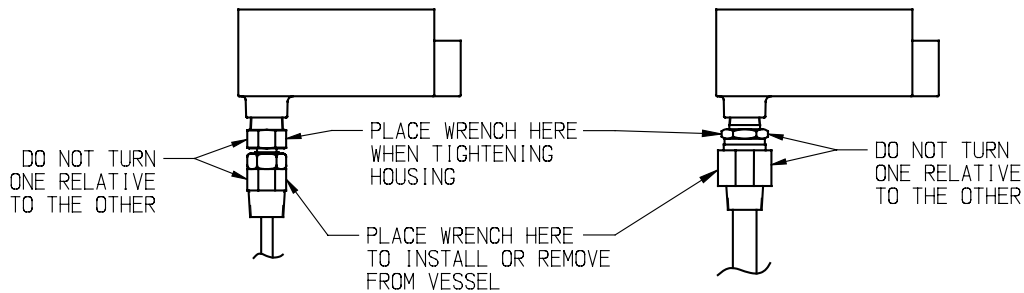

TYPICAL PACKING GLAND CONFIGURATIONS

Upgrade to Universal IV Electronics:

5. Remove the lid from the housing to expose the electronic unit.
6. Loosen the two (2) hold-down screws on the top of the electronic unit.
7. Carefully remove the electronic unit from the housing.
8. Connect the new interconnect cable to the sensing element. Use the blue screw for the center wire and the red screw for the shield wire.



Note: Not all sensing elements use the shield wire connection.

9. Slide the heat-shrink tube over the back end of the sensing element.
10. Apply heat to the heat-shrink tube until it fits tightly on the sensing element.



Note: If the heat-shrink tube cannot be heated, wrap the back end of the sensing element with an insulated electrical tape.

11. If required, install the extension tube over the interconnect cable and thread it clockwise onto the back end of the sensing element and tighten (Use thread sealant on pipe thread connections to prevent galling and to create a weather tight seal)..



Warning: Do not overtighten the packing gland on the sensing element. *See Figure 1.*

12. Insert the interconnect cable through the bottom hub of the housing.

- Thread the extension tube, on the back end of the sensing element, clockwise into the housing and tighten. (Use thread sealant on pipe thread connections to prevent galling and to create a weather tight seal).



Warning: Do not overtighten the packing gland on the sensing element.

- Connect the interconnect cable to the terminal block in the bottom of the housing. Connect the cable's center wire (blue) to the "PROBE" terminal and the cable's shield wire (red) to the "SHLD" terminal.

- Reinstall the electronic unit.



Note: Make sure that the unit is properly seated on the connector socket.

- Tighten the two (2) hold-down screws on the electronic unit.



Caution: Do not over tighten the hold-down screws, 6 in-lbs (0.7 N-m) maximum torque.

- Connect the loop wires to the terminal block on the top of the electronic unit.

- Reinstall the housing lid.



Important: The lid must be fully seated to insure a weather tight seal.



Note: For hazardous (classified) locations, refer to the: Universal IV Installation and Operating Instructions (UIV-LM)

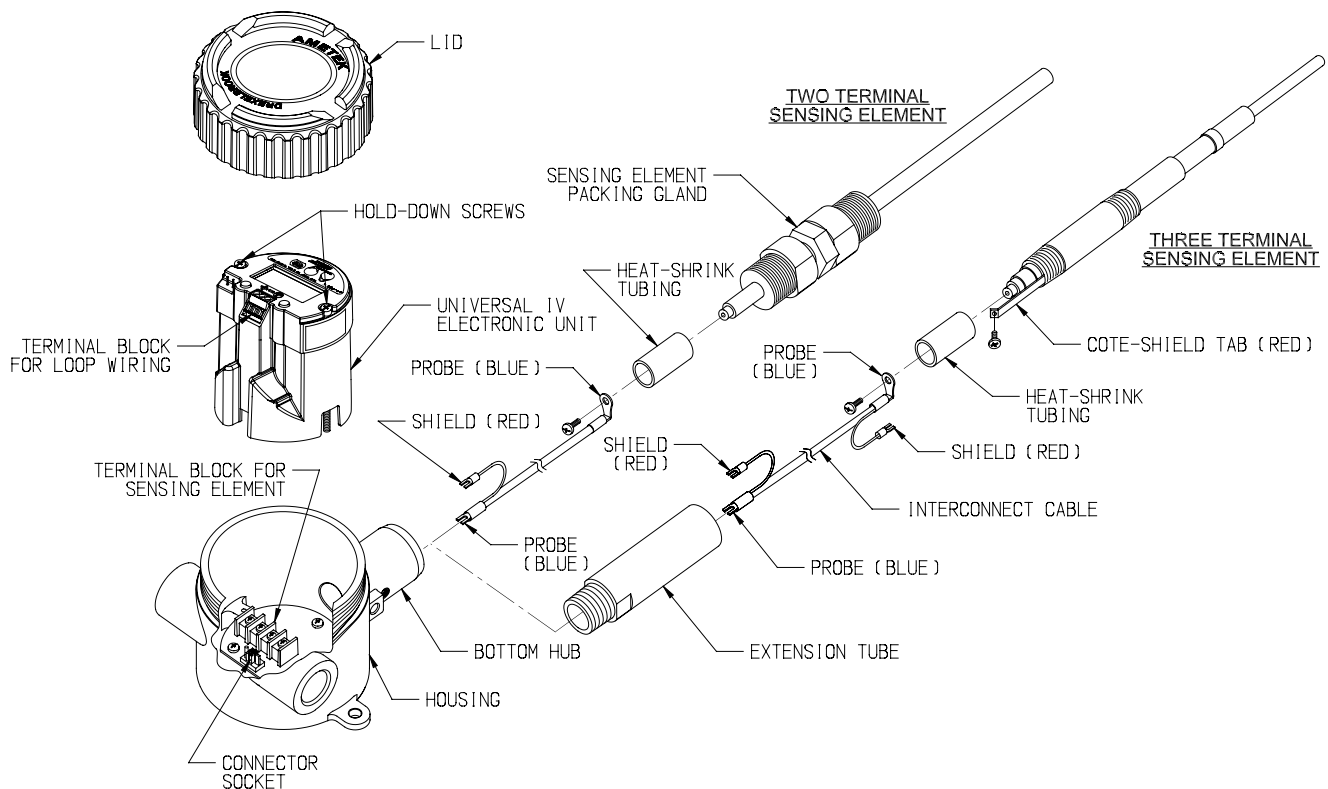

Universal IV Upgrade Package - Remote

The Universal IV integral upgrade package includes:

- Universal IV electronics in housing

Preparing the system for upgrade:

1. Disconnect the loop wires from the existing system.
2. Disconnect the sensing element connections from the transmitter.
3. Remove the housing and transmitter.

Upgrade to Universal IV electronics:

4. Remove the lid from the housing to expose the electronic unit.
5. Loosen the two (2) hold-down screws on the top of the electronic unit.
6. Carefully remove the electronic unit from the housing by grasping the hold-down screws and lifting. (The hold-down screws are captive and will not fall out of the electronic unit).
7. Securely mount the Universal IV housing in place of the old housing.
8. Connect the three-terminal cable from the sensing element to the terminal block in the bottom of the housing.
9. Reinstall the electronic unit.

Note: Make sure that the unit is properly seated on the connector socket.

10. Tighten the two (2) hold-down screws on the electronic unit.



Caution: Do not over tighten the hold-down screws, 6 in-lbs (0.7 N-m) maximum torque.

11. Connect the loop wires to the terminal block on the top of the electronic unit.
12. Reinstall the housing lid.



Important: The lid must be fully seated to insure a weather tight seal.



Note: For hazardous (classified) locations, refer to the: Universal IV Installation and Operating Instructions (UIV-LM)

Remote Installation

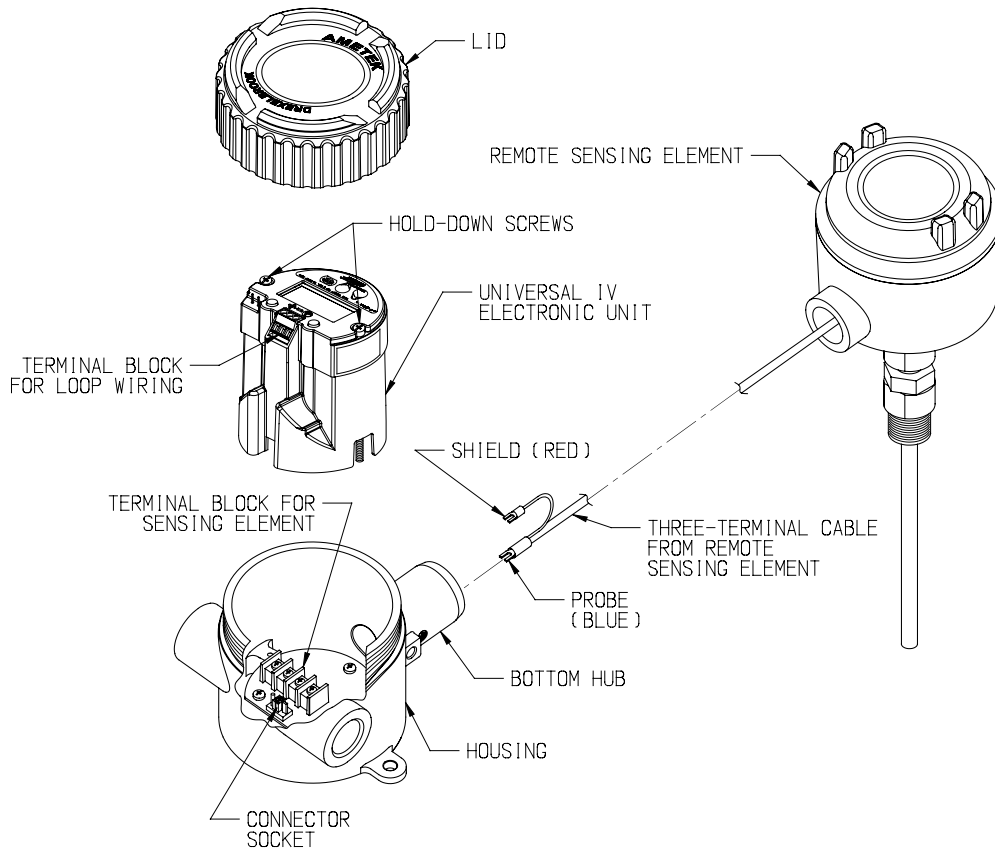

Housing Dimensions

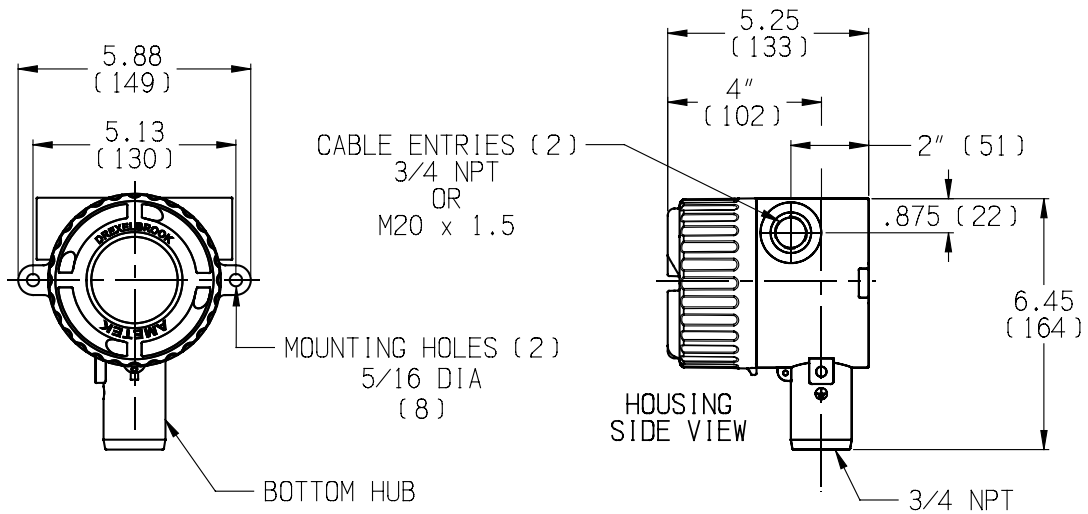

DIMENSIONS ARE IN INCHES
(mm)

TERMS AND CONDITIONS OF SALE

GENERAL: ALL ORDERS ARE SUBJECT TO THE FOLLOWING TERMS AND CONDITIONS. ANY ACCEPTANCE OF ANY OFFER OF BUYER FOR ANY GOODS OR SERVICES IS CONDITIONED UPON THESE TERMS AND CONDITIONS, AND SELLER OBJECTS TO ANY ADDITIONAL OR DIFFERENT TERMS PROPOSED BY BUYER IN ANY DOCUMENT, WHICH SHALL NOT BE BINDING UPON SELLER. No salesman or other party is authorized to bind the AMETEK DREXELBROOK Division of AMETEK, Inc. (hereinafter "Seller") by any agreement, warranty, statement, promise, or understanding not herein expressed, and no modifications shall be binding on Seller unless the same are in writing and signed by an executive officer of Seller or his or her duly authorized representative. Verbal orders shall not be executed until written notification has been received and acknowledged by Seller.

QUOTATIONS: Written quotations are valid for thirty (30) days unless otherwise stated. Verbal quotations expire the same day they are made.

PRICES: All prices and terms are subject to change without notice. Buyer-requested changes to its order ("Orders"), including those affecting the identity, scope and delivery of the goods or services, must be documented in writing and are subject to Seller's prior approval and adjustments in price, schedule and other affected terms and conditions. Orders requiring certified test data in excess of commercial requirements, are subject to a special charge.

ORDER ACCEPTANCE: All Orders are subject to final approval and acceptance by Seller at its office located at 205 Keith Valley Road, Horsham, Pennsylvania 19044.

TERMS OF PAYMENT: Seller's standard terms of payment for Buyers who qualify for credit are net thirty (30) days from date of invoice. All invoices must be paid in United States dollars.

CREDIT: Seller reserves the right at any time to revoke any credit extended to Buyer or otherwise modify terms of payment if Buyer fails to pay for any shipments when due or if in Seller's opinion there is a material adverse change in Buyer's financial condition. Seller may, at its option, cancel any accepted Order if Buyer fails to pay any invoices when due.

DELIVERY: Shipments are F.O.B place of manufacture ("Shipping Point") and the Buyer shall pay all freight, transportation, shipping, duties, fees, handling, insurance, storage, demurrage, or similar charges from Shipping Point. Delivery of goods to common carrier shall constitute delivery and passing of title to the Buyer, and all risk of loss or damage in transit shall be borne by Buyer. Any claims or losses for damage or destruction after such delivery shall be the responsibility of Buyer.

Seller reserves the right to make delivery in installments which shall be separately invoiced and paid for when due, without regard to subsequent deliveries. Delay in delivery of any installment shall not relieve Buyer of its obligation to accept remaining deliveries.

Acknowledged shipping dates are approximate only and based on prompt receipt of all necessary information from Buyer and Buyer's compliance with terms of payment.

TAXES: All sales, excise and similar taxes which Seller may be required to pay or collect with respect to the goods and/or services covered by any Order, shall be for the account of the Buyer except as otherwise provided by law or unless specifically stated otherwise by Seller in writing.

TERMINATION AND HOLD ORDERS: No Order may be terminated by Buyer except upon written request by Buyer and approval by Seller, and if said request is approved by Seller, under the following conditions: (1) Buyer agrees to accept delivery of all of the units completed by Seller through the workday on which Seller receives the written termination request; (2) Buyer agrees to pay to Seller all direct costs and expenses applicable to the portion of the Order that is incomplete.

WARRANTY:

A. **Hardware:** Seller warrants its goods against defects in materials and workmanship under normal use and service for one (1) year from the date of invoice.

B. **Software and Firmware:** Unless otherwise specified, Seller warrants for a period of one (1) year from date of invoice that standard software or firmware, when used with Seller specified hardware, shall perform in accordance with Seller's published specifications. Seller makes no representation or warranty, expressed or implied, that the operation of the software or firmware shall be uninterrupted or error-free, or that functions contained therein shall meet or satisfy the Buyer's intended use or requirements.

C. **Services:** Seller warrants that services, including engineering and custom application, whether provided on a fixed cost or time and material basis, shall be performed in accordance with generally accepted industry practices.

D. **Remedies:** Seller's liability under this section is restricted to replacing, repairing, or issuing credit (at Seller's option) for any returned goods and only under the following conditions: (1) Seller must be promptly notified, in writing, as soon as possible after the defects have been noted by the Buyer, but not later than (1) year from date of invoice from Seller; (2) The defective goods are to be returned to the place of manufacture, shipping charges prepaid by the Buyer; (3) Seller's inspection shall disclose to its satisfaction that the goods were defective in materials or workmanship at the time of shipment; (4) Any warranty service (consisting of time, travel and expenses related to such services) performed other than at Seller's factory, shall be at Buyer's expense.

E. **Repaired/Reconditioned Goods:** As to out-of-warranty goods which Seller has repaired or reconditioned, Seller warrants for a period of sixty (60) days from date of its invoice only new components replaced in the most recent repair/reconditioning.

F. **Returns and Adjustments:** No goods may be returned unless authorized in advance by Seller and then only upon such conditions to which Seller may agree. Buyer must obtain an RMA (Return Material Authorization) number from Seller prior to any return shipment and such RMA number must appear on the shipping label and packing slip. Buyer shall be responsible for the returned goods until such time as Seller receives the same at its plant and for all charges for packing, inspection, shipping, transportation, or insurance associated with returned goods. In the event that credit for returned goods is granted, it shall be at the lesser of the then current prices or the original purchase price. Claims for shortage or incorrect material must be made within five (5) days after receipt of shipment.

ALL OTHER WARRANTIES, FOR ANY OF SELLER'S GOODS OR SERVICES, WHETHER ORAL, WRITTEN, EXPRESS, IMPLIED, STATUTORY OR OTHERWISE, INCLUDING WITHOUT LIMITATION ANY IMPLIED WARRANTY OF MERCHANTABILITY OR FITNESS FOR PURPOSE ARE EXCLUDED.

INTELLECTUAL PROPERTY: Seller's sale of goods or provision of related documentation or other materials to Buyer shall not transfer any intellectual property rights to Buyer unless Seller specifically agrees to do so in writing. Seller shall retain ownership of all applicable patents, trademarks, copyrights and other intellectual property rights. Buyer shall not use, copy or transfer any such items in violation of Seller's intellectual property rights or applicable law, or for any purposes other than that for which the items were furnished.

Seller shall defend any lawsuit brought against the Buyer based on a claim that the design or construction of the goods sold hereunder by Seller infringe any United States or Canadian Patent, Copyright or Mask Work Registration, provided that Buyer promptly notifies Seller of such claim in writing and further provided that, at Seller's expense, (1) Buyer gives Seller the sole right to defend or control the defense of the suit or proceeding, including settlement, and (2) Buyer provides all necessary information and assistance for that defense. In the event of a charge of infringement, Seller's obligation under the agreement shall be fulfilled if Seller, at its option and expense, either (i) settles such claim; (ii) procures for Buyer the right to continue using such goods; (iii) replaces or modifies goods to avoid infringement; or (iv) accepts the return of any infringing goods and refunds their purchase price; or (iv) defends against such claim.

If Buyer furnishes specifications or designs to Seller, the obligations of Seller set forth above shall not apply to goods made by Seller using such specifications or designs, and Buyer shall defend, indemnify and hold Seller harmless against any third party claims for infringement which arise out of Seller's use of specifications or designs furnished by Buyer.

SOFTWARE LICENSE: If goods purchased hereunder include software ("Software"), Buyer may use the Software only as part of the goods. Buyer may not use, copy, or transfer any of the Software except as may be permitted under the applicable License Agreement provided with the goods. Buyer's right to use, copy or transfer the Software shall terminate upon termination of Buyer's right to use the goods.

PACKAGING/WEIGHTS AND DIMENSIONS: Buyer specified packing or marking may be subject to additional charges not otherwise included in the price of the goods. Published weights and dimensions are estimates or approximate only and are not warranted.

FORCE MAJEURE: Seller shall not be responsible for delays in delivery or any failure to deliver due to causes beyond Seller's control, including but not limited to the following items: acts of God, war, terrorism, mobilization, civil commotion, riots, embargoes, domestic or foreign governmental regulations or orders, governmental priorities, port congestion, acts of the Buyer, its agents or employees, fires, floods, strikes, lockouts and other labor difficulties, shortages of or inability to obtain shipping space or transportation, inability to secure fuel, supplies or power at current prices or on account of shortages thereof, or due to limitations imposed by the extent of availability of Seller's normal manufacturing facilities.

If a delay excused per the above extends for more than ninety (90) days and the parties have not agreed upon a revised basis for continuing providing the goods or services at the end of the delay, including adjustment of the price, then Buyer, upon thirty (30) days' prior written notice to Seller may terminate the Order with respect to the unexecuted portion of the goods or services, whereupon Buyer shall promptly pay Seller its reasonable termination charges upon submission of Seller's invoices thereof.

LIMITATION OF LIABILITY: Seller's liability for any claim of any kind, except infringement of intellectual property rights, shall not exceed the purchase price of any goods or services which give rise to the claim. **SELLER SHALL IN NO EVENT BE LIABLE FOR BUYER'S MANUFACTURING COSTS, LOST PROFITS, LOSS OF USE OF THE GOODS OR SERVICES, COST OF CAPITAL, COST OF SUBSTITUTE GOODS, FACILITIES, SERVICES OR REPLACEMENT POWER, DOWNTIME COSTS, CLAIMS OF BUYER'S CUSTOMERS FOR DAMAGES, OR OTHER SPECIAL, PROXIMATE, INCIDENTAL, INDIRECT, EXEMPLARY OR CONSEQUENTIAL DAMAGES.** Any action against Seller must be brought within eighteen (18) months after the cause of action accrues. These disclaimers and limitations of liability shall apply regardless of the form of action, whether in contract, tort or otherwise, and further shall extend to the benefit of Seller's vendors, appointed distributors and other authorized resellers as third-party beneficiaries.

PROHIBITION FOR HAZARDOUS USE: Goods sold hereunder generally are not intended for application in and shall not be used by Buyer in the construction or operation of a nuclear installation or in connection with the use or handling of nuclear material, or for any hazardous activity or critical application, where failure of a single component could cause substantial harm to persons or property, unless the goods have been specifically approved for such a use or application. Seller disclaims all liability for any loss or damage resulting from such unauthorized use and Buyer shall defend, indemnify and hold harmless the Seller against any such liability, whether as a result of breach of contract, warranty, tort (regardless of the degree of fault or negligence), strict liability or otherwise.

EXPORT CONTROL: Buyer shall comply with all export control laws and regulations of the United States, and all sales hereunder are subject to those laws and regulations. Seller shall not be named as shipper or exporter of record for any goods sold hereunder unless specifically agreed to in writing by Seller. At Seller's request, Buyer shall furnish Seller with end-use and end-user information to determine export license applicability. Buyer warrants, in accordance with U.S. Export Law, that goods sold hereunder shall not be destined for facilities or activities involving nuclear, chemical or biological weapons, or related missile delivery systems in named prohibited regions or countries.

GOVERNING LAW: Seller intends to comply with all laws applicable to its performance under any order. All matters relating to interpretation and effect of these terms and any authorized changes, modifications or amendments thereto shall be governed by the laws of the Commonwealth of Pennsylvania. No government contract regulations or clauses shall apply to the goods or services, this agreement, or act to bind Seller unless specifically agreed to by Seller in writing.

NON-WAIVER BY SELLER: Waiver by Seller of a breach of any of these terms and conditions shall not be construed as a waiver of any other breach.

SEVERABILITY AND ENTIRE AGREEMENT: If any provision of these terms and conditions is unenforceable, the remaining terms shall nonetheless continue in full force and effect. This writing, together with any other terms and conditions Seller specifically agrees to in writing, constitutes the entire terms and conditions of sale between Buyer and Seller and supercedes any and all prior discussions, and negotiations on its subject matter.



205 Keith Valley Road, Horsham, PA 19044
U.S. and Canada: 1-800-553-9092
24-Hour Service: 1-800-527-6297
International: +1 215-674-1234
Fax: +1 215-674-2731
E-mail: drexelbrook.info@ametek.com
Website: www.drexelbrook.com