

DREXELBROOK®

A Leader in Level Measurement

Quick Start Guide

For the

Universal IV™ CM Model

2-Wire, 4-20 mA, Water Cut Meter
with HART® Protocol



For Assistance Call 1-800-527-6297
Outside North America + 215-674-1234

AMETEK®
DREXELBROOK

EDO# 7-14-108
UIVCM-QS-LM
Issue # 2



205 Keith Valley Road, Horsham, PA 19044
U.S. and Canada: 1-800-553-9092
24-Hour Service: 1-800-527-6297
International: +1 215-674-1234
Fax: +1 215-674-2731
E-mail: drexelbrook.info@ametek.com
Website: www.drexelbrook.com

Table of Contents

| | |
|--|-----------|
| Section 1: Installation | 1 |
| 1.1 System Description..... | 1 |
| 1.2 Unpacking | 1 |
| 1.3 Safety Information..... | 1 |
| 1.4 Commissioning - Start Up Checklist..... | 2 |
| 1.5 Installation | 3 |
| 1.6 Mounting The Electronic Unit..... | 5 |
| 1.7 Wiring the Electronic Unit | 8 |
| 1.8 Wiring The Sensing Element..... | 9 |
| | |
| Section 2: Configuration / Calibration | 11 |
| 2.1 Configuration And Calibration With Drexelbrook Software, HRTwin..... | 11 |
| 2.2 One Shot® Calibration Trim Using Hrtwin Software..... | 12 |
| 2.3 Range Change..... | 13 |
| 2.4 Save/Print Entries..... | 14 |
| 2.5 Calibration / Configuration Via Display / Keypad | 15 |
| | |
| Section 3: Hazardous Location Approval Supplementary Instructions | 18 |
| 3.1 General safety information | 18 |
| 3.2 The Compartment Cover | 19 |
| 3.3 Standards and Approvals | 20 |

AMETEK Drexelbrook makes no warranty of any kind with regard to the material contained in this manual, including, but not limited to, implied warranties or fitness for a particular purpose. Drexelbrook shall not be liable for errors contained herein or for incidental or consequential damages in connection with the performance or use of material.



IMPORTANT NOTICE

This quick start guide provides basic guidelines for the Drexelbrook Universal IV CM Model Water Cut Meter. Refer to the Universal IV CM Model Installation and Operation Manual for more detailed instructions.

Section 1: Installation

1.1 System Description

The instructions in this quick start guide are for the AMETEK Drexelbrook Universal IV CM Model Water Cut Meter for measurement of the percentage of water in oil. Each AMETEK Drexelbrook Universal IV CM system consists of a two-wire, 4-20mA electronic unit and a 700 series sensing element. Communication with the device is done by either an onboard keypad or with a laptop via HART protocol.

1.2 Unpacking

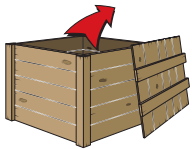

Carefully remove the contents of the carton and check each item against the packing list before destroying any packing material. If there is any shortage or damage, report it immediately to the factory.

1.3 Safety Information



- Installation, start up, and service should only be performed by personnel trained in explosive atmosphere installations
- Substitution of components may impair intrinsic safety
- Live maintenance should only be carried out by skilled personnel trained in explosion protection methods
- Test equipment used to perform live maintenance must be certified to use in the associated hazardous area
- When installed as an intrinsically safe device per the agency control drawings, the housing cover may be safely opened
- Only cables supplied by Drexelbrook should be used as the use of other cables can result in unstable performance.

Explosionproof or Flameproof Installations

- No live maintenance is permitted
- Disconnect power to the device and check that the atmosphere is clear of hazardous substances

1.4 Commissioning - Start Up Checklist

DO NOT connect power until you have gone through the checklist below

- Are the wetted components resistant to the corrosive properties of the tank product?
- Does the information given on the nameplate correspond with the application?
- Ex d applications: Have you connected the equipotential bonding system correctly?
- Ex i applications: Are you using intrinsic barrier within the correct parameters?
- Did you install cable entries of the correct internal diameter so there is a good seal around the cable?
- Are the cable glands suitably certified per the application and the hazardous area parameters?
- Do not use the earth terminal in the wiring compartment; use the equipotential bonding system.

1.5 Installation

Use the following mounting and installation instructions so that the sensing element will operate properly.

- Sensing element should be mounted in a section of pipe as close to center and as parallel to the pipe as possible
- Factory calibration assumes mounting on the pipe centerline and in the correct size pipe
- Vertical mounting (tip down) is preferred but not essential
- Gas bubbles must be excluded from the active area by maintaining pressure (if necessary, a degasser upstream) as bubbles decrease system accuracy
- Do not take sensing element apart or loosen the packing glands
- In large pipe installations (over 8 inches) the length of the cote shield section must be long enough that the cutout in the concentric tube is in the actual flow of oil
- For large pipe with no bend (18 inches or larger) it is possible to mount the sensing element at 45 degree angle to provide sufficient flow through the shield.

1.5 Installation (Continued)

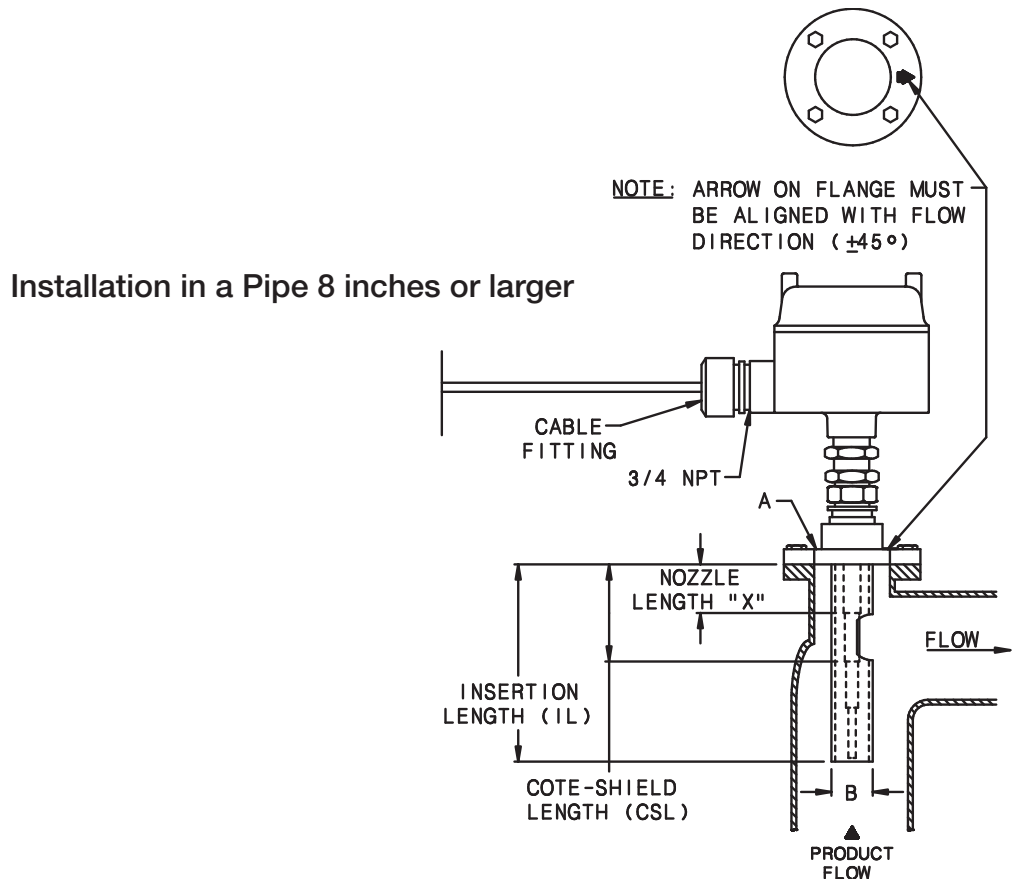

Installation in a Pipe 18 inches or larger

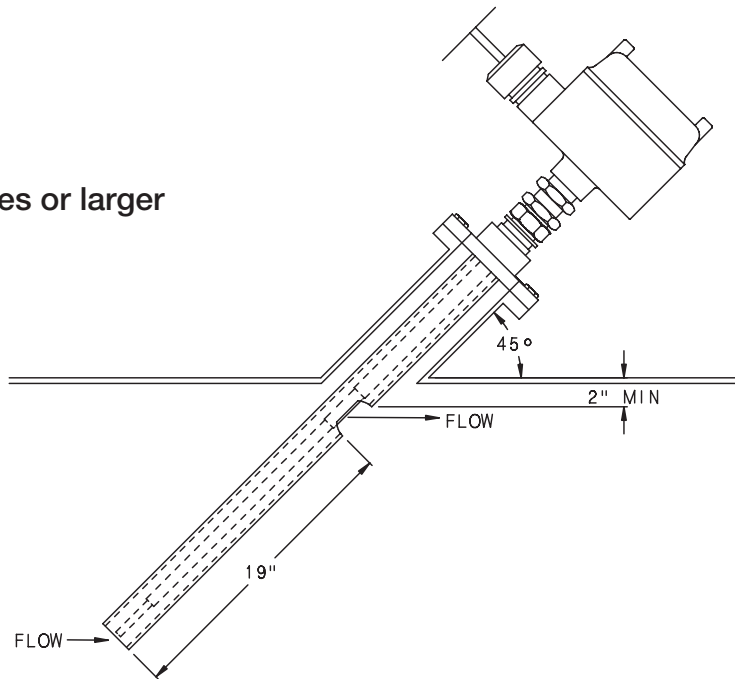

Figure 1-1
Recommended Installation

1.6 Mounting The Electronic Unit

- The integral electronic unit is mounted with the sensing element
- The remote electronic unit is designed for field mounting, but should be mounted in a location free from vibration, corrosives, and any mechanical damage
- Rated temperatures for mounting: mount the UIV CM in a reasonably accessible location with ambient temperatures between -40°F and 167°F (-40°C and 75°C)
- When installing conduit to electronic unit, be sure that vertical conduit runs will not cause water to enter the electronic unit housing as show below

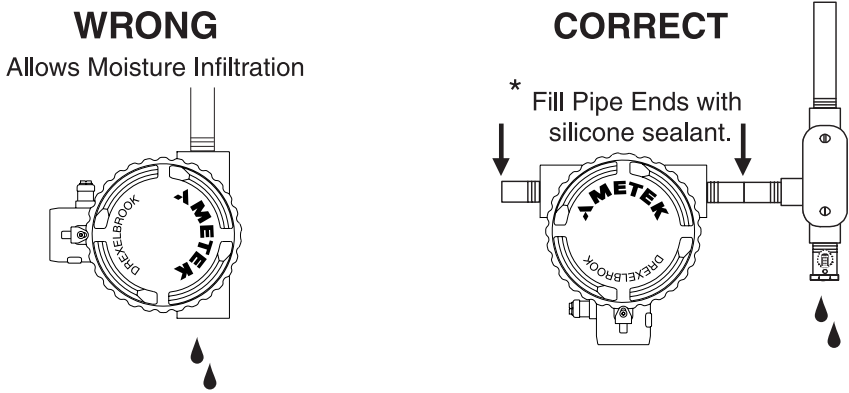
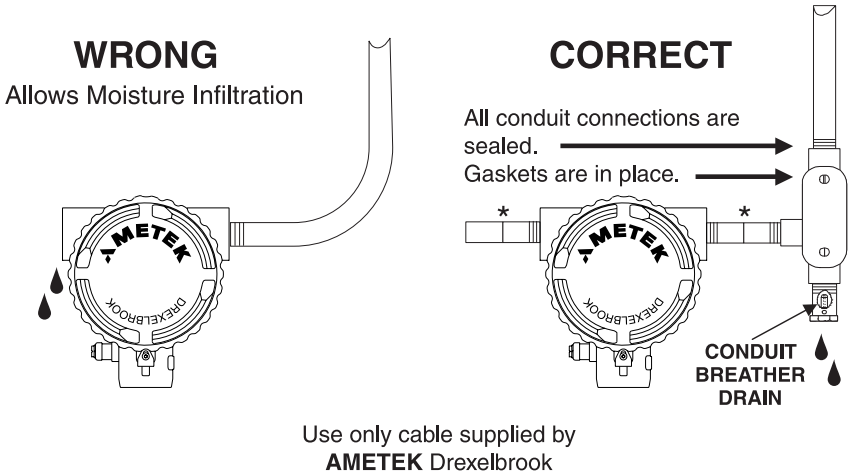
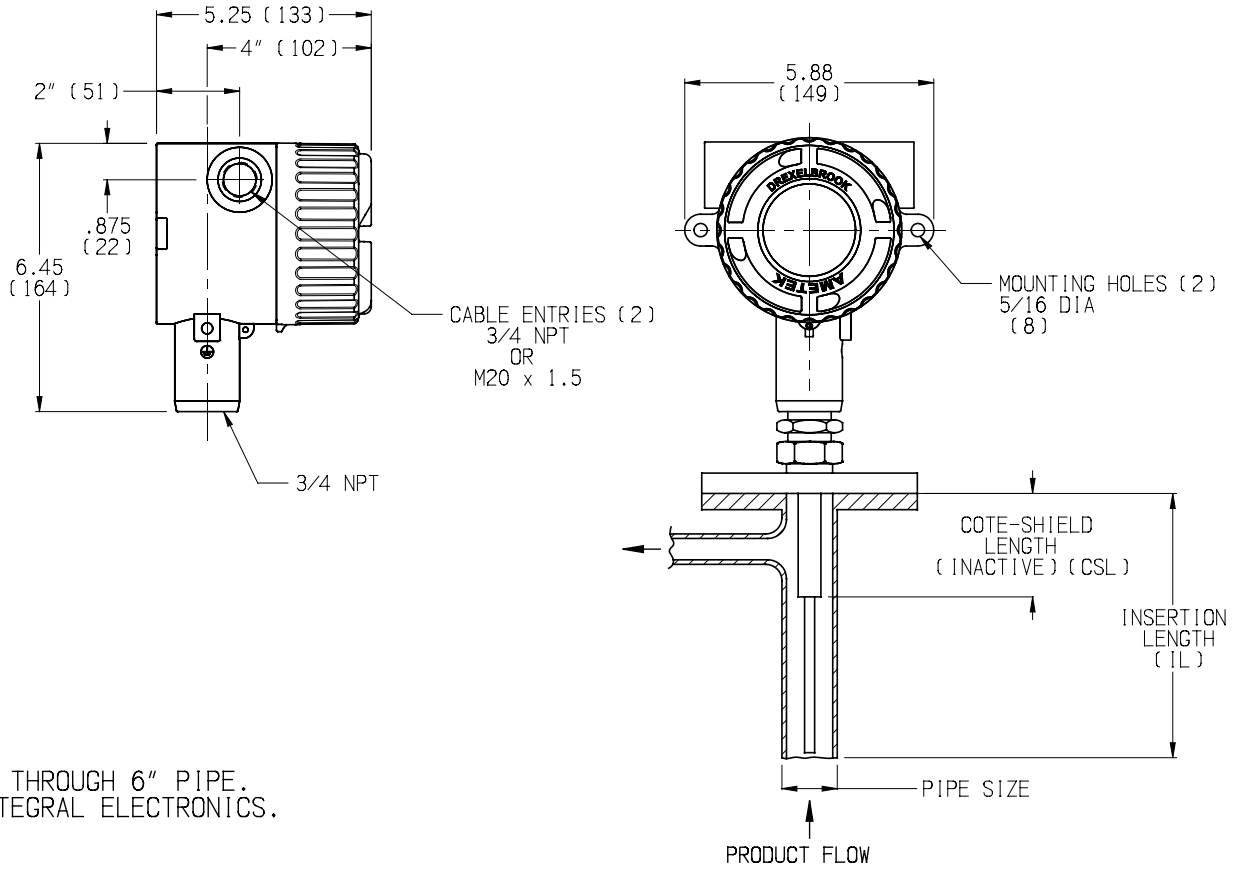

Figure 1-2
Recommended Conduit Installation

1.6 Mounting the Electronic Unit (Continued)

Integral System Mounting



- NOTES:
1. 1" THROUGH 6" PIPE.
2. INTEGRAL ELECTRONICS.

Figure 1-3
Integral Mounting Dimensions

1.6 Mounting the Electronic Unit (Continued)

Remote System Mounting

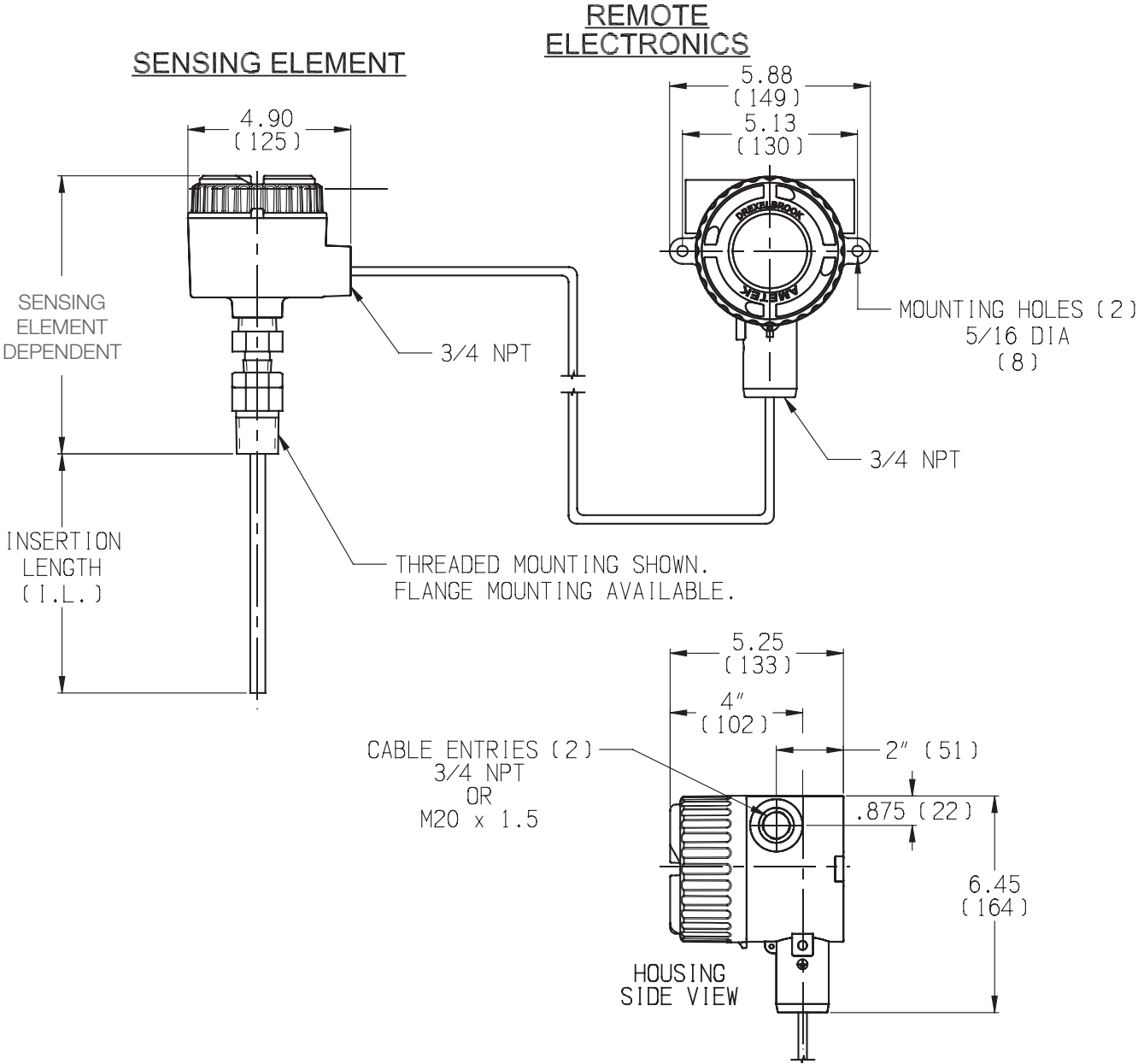

DIMENSIONS ARE IN INCHES
(mm)

Figure 1-4
Remote Mounting Dimensions

1.7 Wiring the Electronic Unit

- Signal connections are made to the 3 terminal block on the front of the chassis
- Due to low power consumption, only light gauge wiring is needed; shielded twisted pair cables recommended
- Integral units are pre-wired to the sensing element at the factory. See Figure 2-5
- See Figure 2-6 for wiring connections to the remote unit
- The cable from the sensing element is connected to the terminal strip below the instrument chassis



CAUTION - Before using Intrinsic Safety Barrier read manufacturer instructions for barrier operation

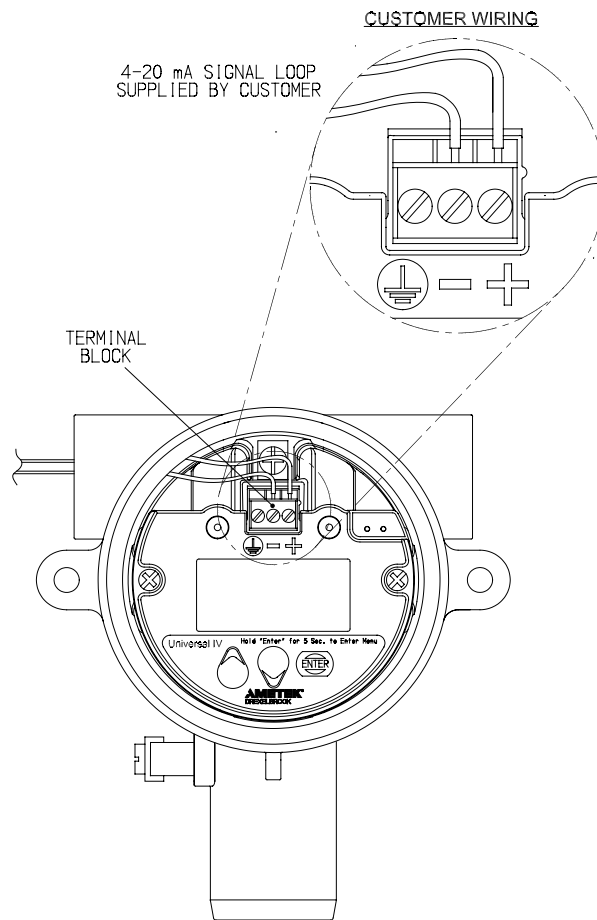

Figure 1-5
Universal IV Wiring Connections

1.8 Wiring The Sensing Element

- Cable connections to the remote sensing element are shown in Figure 2-6
- Do not connect the cable to the sensing element until after the sensing element has been installed in the vessel and the housing has been secured

Integral System Sensing Element Wiring

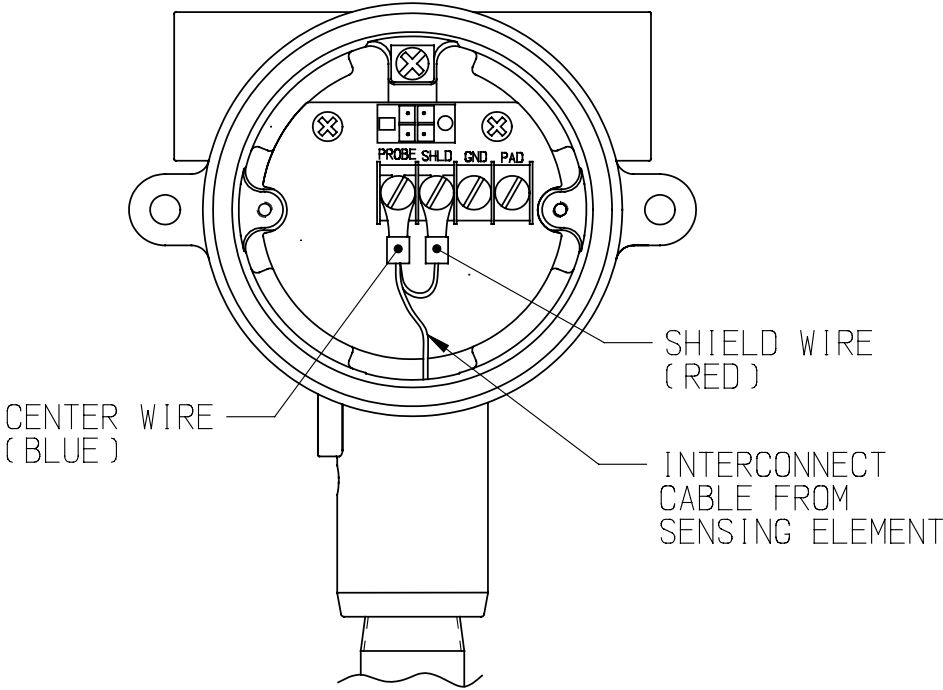

Figure 1-6
Universal IV Wiring Connections Integral Mounting

1.8 Wiring the Sensing Element (Continued)

Remote System Sensing Element Wiring

ELECTRONIC UNIT REMOVED FOR CLARITY

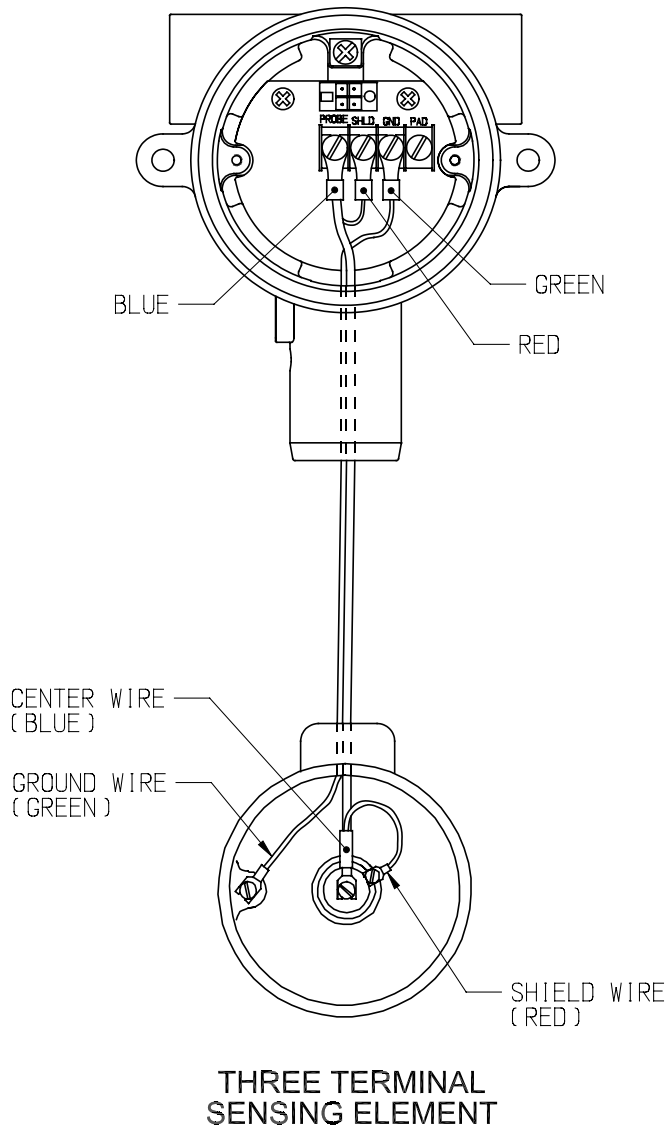

Figure 1-7
Universal IV Wiring Connections, Remote Mounting

Section 2: Configuration / Calibration

2.1 Configuration And Calibration With Drexelbrook Software, HRTwin

- Install USB Modem - HART Modems are available from third party vendors; refer to directions supplied by modem manufacturer
- Install Windows version of HRTWin software
 - Download software from www.drexelbrook.com
 - If program does not "Auto Run" select file from computer and run set up manually
 - Follow instructions in Set Up to create program file
 - Once loaded, double click HRTWin icon and program will run
 - Select communication port and click OK
 - Once port is selected, the on screen prompts will run user through process of communication with unit
- Function Keys - the following describe the function buttons:
 - Read Transmitter (F3 button) - reads all pertinent data from transmitter and displays on screen
 - Write to Transmitter (F5 button) - sends new or edited configuration data to transmitter
 - Real Time View (F4 button) - displays real time values of water %, capacity, loop current, and status
- Configuration - involves downloading information to HART protocol transmitter specific to application being measured
 - Begin configuration by using Tag ID (8 characters) to identify the unit or vessel
 - Use Scratchpad (32 characters) to record date of calibration or other notes
 - Edit Damping Time from 0-90 seconds if desired
 - Click Write to Transmitter



All Drexelbrook Universal IV CM Model Water Cut Meter instruments are calibrated at the factory according to size of pipe and density of oil. DO NOT change the factory calibration without obtaining data that indicates a calibration change is necessary. Consult the factory at 1-800-527-6297 if you believe a calibration change is needed.

2.2 One Shot® Calibration Trim Using Hrtwin Software

- With Pc Connected to the signal loop, click on Real Time View button to open screen
- Take sample of fluid from as close to probe as possible. Use a sampling bomb if the stream temperature is greater than 150F
- Read and record water percentage from "Real Time View" as the sample is being taken
- After determining actual water percentage, close "Real Time View" and open "Calibration Screen" by clicking on the Cut Monitor Calibration button
- Enter % water reading, recorded at the time of sampling in the "Indicated Water" box. Enter the result in the "Sampled Water" box and click on the Calibrate button
- Click on Write to Transmitter button to install revised calibration
- Depending on the range, if the original calibration and measured sample differed by more than 2.5% another iteration will probably be required

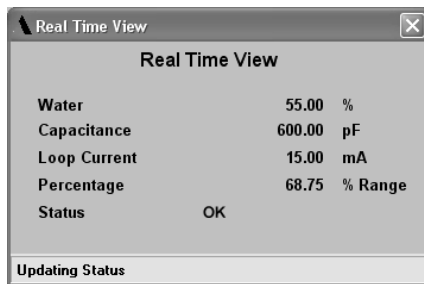

Figure 2-1
RTV Window

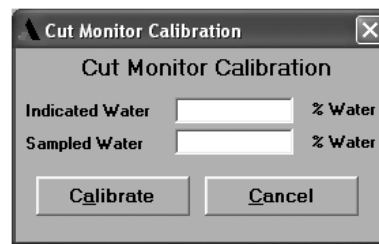

Figure 2-2
Calibration Window

2.3 Range Change

- It is possible to reduce the span of an existing calibration by lowering the % water URV on the Menu Screen
- If the reduction in span is greater than 20-30% of range, better accuracy can be achieved by changing the input/output curve to a lower range
- To re-range the instrument it is necessary to select a different input curve. This procedure can be performed on an installed instrument or in the shop with the electronic unit itself

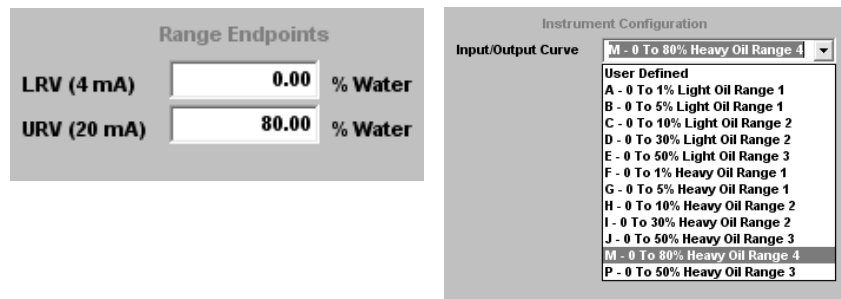

Figure 2-3
Captures from Main Screen

2.4 Save/Print Entries

- All values developed in this configuration/calibration procedure may be saved to be reloaded into another transmitter or printed as a hard copy
- Pop up screens come from selection in the FILE pull down at the top left of the PC menu
- Copies are saved in both .Universal IV CM file and .txt files
- The .Universal IV CM file will download into a transmitter through the OPEN command while .txt files can be printed using PRINT command

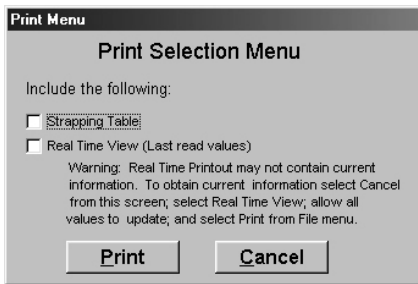

Figure 2-4
Print Pop-up from Menu

AMETEK Drexelbrook
 205 Keith Valley Road
 Horsham, PA 19044
 Telephone: 215-674-1234
 FAX: 215-674-2731
 Service: 800-527-6297

| | |
|----------------------|-----------------------|
| Tag-ID: LT-DEMO | Serial Number: 123456 |
| Scratch Pad: | Software Version: 6.0 |
| Damping Time: 0 sec. | Range Position: 4 |

| | |
|--|----------------------------|
| Instrument Configuration | Range Endpoints |
| Input/Output Curve: M - 0 To 80% Heavy Oil Range 4 | LRV (4 mA): 0.00 % Water |
| | URV (20 mA): 80.00 % Water |

Real Time View

| | |
|----------------|-----------|
| Percent Water: | 55.00 % |
| Capacitance: | 600.00 pF |
| Loop Current: | 15.00 mA |
| Percentage: | 68.75 % |
| Status: | OK |

Input/Output Table

Number of Points: 15

| Input pF | Output % Water |
|-------------|-------------------|
| 40.00 | 0.00 |
| 56.20 | 10.00 |
| 79.00 | 23.00 |
| 122.20 | 35.00 |
| 189.00 | 40.00 |
| 256.00 | 42.00 |
| 395.00 | 50.00 |
| 600.00 | 55.00 |
| 750.00 | 57.00 |
| 900.00 | 60.00 |
| 1100.00 | 65.00 |
| 2400.00 | 70.00 |
| 2700.00 | 75.00 |
| 2900.00 | 80.00 |
| 3450.00 | 83.00 |

2.5 Calibration / Configuration Via Display / Keypad

- All function in the PC software except Save/Print re accessible via the display/keypad
- To enter the Configuration Menu follow these steps
- Press and hold the ENTER button for approximately 5 seconds
- Use the UP and DOWN buttons to scroll through the available selections
- Press ENTER to access sub-menu items
- Use UP and DOWN buttons to adjust settings - settings that can be adjusted will be flashing
- Press ENTER to accept the adjustment or press and hold ENTER for 5 seconds to exit to previous menu

| Menu Function (display abbreviation) | "Values (display abbreviat | Description |
|--|--|--|
| "Fct 1.00 Water Cut Ranges (RANGE)" | | Select the water cut range for optimal measurement |
| | 0 to 1% water in Light Oil (LIGHT A) | 'Light Oil' is defined as oil with API Gravity less than 25. Heavy Oil is defined as oil with API Gravity greater than 25. |
| | 0 to 5% water in Light Oil (LIGHT B) 0 to 10% water in Light Oil (LIGHT C) 0 to 30% water in Light Oil (LIGHT D) 0 to 50% water in Light Oil (LIGHT E) 0 to 1% water in Heavy Oil (HEAVY F) 0 to 5% water in Heavy Oil (HEAVY G) 0 to 10% water in Heavy Oil (HEAVY H) 0 to 30% water in Heavy Oil (HEAVY I) 0 to 50% water in Heavy Oil (HEAVY J) 0 to 80% water in Heavy Oil (HEAVY M) - Default | |
| | CUSTOM | Custom range requires a custom strapping table. See Fct 3.00 |
| "Fct 2.00 Calibration (CAL)" | | Enter this menu to calibrate the unit |
| "Fct 2.01 Indicated Calibration Point (IND CAL)" | % water - 0.0 Default | Enter the water cut reading captured at the time of taking the sample for calibration measurement |
| "Fct 2.02 Actual Calibration Point (ACT CAL)" | % water - 0.0 Default | Enter the actual water cut reading verified by another method of water cut measurement |
| "Fct 3.00 Strapping table (STRAP)" | | Use this strapping table menu to define a custom range if selected in FCT 1.00. Otherwise the correct strapping table is automatically loaded when range is selected in FCT 1.00. Default values are for 'HEAVY M' range |
| "Fct 3.01 Maximum points (MAX PNT)" | 15 (Default) | Enter the total number of points in the strapping table which is range dependent |
| "Fct 3.02 Point number index (INDEX)" | "1..MAX PNT 1 (Default)" | Enter the point number index |

2.5 Calibration / Configuration via Display / Keypad (Continued)

| | | |
|--|-------------------|---|
| "Fct 3.03 Input value in PF (INPT #) " | Value in PF | Enter the capacitance value in pF |
| "Fct 3.04 Output value in water cut% (OUT #)" | Value in % water | Enter the cut value associate with the capacitance in pF and point index. Repeat FCT 3.02 to FCT 3.04 until all points are entered in the strapping table |
| "Fct 4.00 Output (OUTPUT)" | | Configure the output from the unit including LRV, URV, damping and fixed output |
| "Fct 4.01 Lower Range Value (LRV)" | 0.0 (Default) | Enter the lower range value in % water equivalent to 4mA output |
| "Fct 4.02 Upper Range Value (URV)" | 80.0 (Default) | Enter the upper range value in % water equivalent to 20mA output |
| "Fct 4.03 Damping in Seconds (DAMPING)" | 0.0 (Default) | Enter damping in seconds to delay and filter (software RC filter) the output in case of rapid water cut variations |
| "Fct 4.04 4mA Trim (TRIM 4)" | 4.00 (Default) | Use this menu to calibrate the 4 mA output which is not common practice. Requires calibrated meter to measure actual current output |
| "Fct 4.05 20mA Trim (TRIM 20)" | 20.00 (Default) | Use this menu to calibrate the 20 mA output which is not common practice. Requires calibrated meter to measure actual current output |
| "Fct 4.06 Fixed Output (LOCK mA)" | 0.00 (Default) | Use this menu to fix the output to a certain mA value regardless of the measurement. Enter the value in mA. The output will stay at this value until exiting the menu or if display times out in approx. 30 seconds |
| "Fct 4.07 Device ID (POLL)" | 0 (Default) | Enter the device ID to be used on the HART loop. Each device on the loop must have a unique device ID. Change only for multi-drop configuration |
| "Fct 5.00 Display (DISPLAY)" | | Setup the parameter(s) to be displayed on the unit during operation |
| "Fct 5.01 Toggle the display (TOGGLE?)" | NO (Default) | Toggle between enabled parameters. YES or NO |
| "Fct 5.02 Water Cut (H2O)" | ENABLE (Default) | Enable or disable water cut measurement display |
| "Fct 5.03 Capacitance (CAP)" | DISABLE (Default) | Enable or disable capacitance measurement in pF |
| "Fct 5.04 Calculated current (4--20)" | DISABLE (Default) | Enable or disable the calculated current output |
| "Fct 6.00 Service (SERVICE)" | | Use this menu for troubleshooting and service |

2.5 Calibration / Configuration via Display / Keypad (Continued)

| | | |
|--|----------------|---|
| "Fct 6.01 Restore factory default (RST FAC)" | NO (Default) | Select YES to restore factory default in which case all parameters will be replaced with factory default setting. Restoring the factory default will initiate this message on the display 'DEFAULT PARAMS SET' until power is cycled. |
| "Fct 6.02 Pad Capacitor in PF (PAD CAP)" | 30.0 (Default) | Enter the value of an external capacitor that must be connected to the unit. Padding capacitors are used to reduce the sensing element standing capacitance in order to improve the measurement resolution |
| "Fct 6.03 Contrast (CONTRST)" | 0 (Default) | 0 is the highest contrast. 20 is the lowest contrast |
| "Fct 6.04 Parameter Number (PAR NUM)" | 0 | 0 to 65535. Contact factory |
| "Fct 6.05 Parameter Offset (PAR OFS)" | 0 | Contact factory |
| "Fct 6.06 Parameter Value (PAR VAL)" | 44 | Contact factory |

Section 3: Hazardous Location Approval Supplementary Installation & Operating Instructions

3.1 General safety information

This document contains installation instructions for potentially explosive atmosphere applications.

The Universal U IV is approved for use in hazardous locations when properly installed. Control drawings detailing installation guidelines are available in *Section 8*.

Always Install to Local Codes / Requirements / Directives as Mandated by the Authority Having Jurisdiction.

The aluminum enclosure must be protected from mechanical friction and impact that could cause ignition capable sparks.

3.1.2 Warning



- Installation, Start-Up, and Service should only be performed by personnel trained in explosive atmosphere installations.
- Substitution of Components May Impair Intrinsic Safety.

3.1.3 Device Description

The Universal IV is a Continuous Level Measurement System. Measurements are displayed via remote communications or an integrated display screen.

3.1.4 Electrical connection

WARNING! Read the following information carefully.



- Live Maintenance should only be carried out by Skilled Personnel trained in explosion protection methods.
- Test Equipment used to perform “Live Maintenance” must be certified to use in the associated hazardous area.

Intrinsically Safe Installations



When the Universal IV is installed as an intrinsically safe device per the agency control drawings, the housing cover may be safely opened. For system configuration, remove the view port housing cover to access the display keypad for local system configuration.

Explosionproof or Flameproof Installations



No Live maintenance is permitted. Disconnect power to the device and check that the atmosphere is clear of hazardous substances.

3.1.5 Commissioning

Start-up checklist



Do not connect power until you have gone through the checklist below

1. Are the wetted components (gasket, flange and sensing element) resistant to the corrosive properties of the tank product?
2. Does the information given on the nameplate correspond with the application?
3. Ex d applications: Have you connected the equipotential bonding system correctly?
4. Ex i applications: Are you using an intrinsic barrier within the correct parameters?
5. Did you install cable entries of the correct internal diameter so that there is a good seal around the cable? Are the cable glands suitably certified per the application and the hazardous area parameters?
6. Do not use the earth terminal in the wiring compartment: use the equipotential bonding system.

3.2 The Compartment Cover

Viewport Cleaning: The viewport is made of Borosilicate glass and can be cleaned with any common glass cleaning product (e.g.: Windex™, Isopropyl alcohol, etc.) that is suitable for the Class and Division rating of the specific system installation.

3.2.1 Opening the cover



Procedure

1. Unscrew cover stop, if applicable
2. Unscrew terminal compartment cover

3.2.2 Closing the cover

Warning: Ex d [ia] applications

Check that the terminal compartment cover is screwed tight and the cover stop (if applicable) is fastened tightly to the cover.

3.3 Standards and Approvals

3.3.1 FM US Approvals - Install per 420-0004-412-CD

The Universal IV Level Transmitter is rated as Intrinsically Safe for Class I, II and III, Groups A-G and Class I, Zone 0, Group IIC, in accordance with drawing 420-0004-412-CD; Nonincendive Class I, Division 2, Groups A-D Hazardous (Classified) Locations.

Furthermore, the Integral version is rated as Explosionproof for Class I, Division 1, Groups C & D; Dust Ignitionproof for Class II & III, Division 1, Groups E-G and Class I, Zone 1, Group IIB Hazardous (Classified) Locations with an integral sensor that is Intrinsically Safe for Class I, II & III, Groups A-G and Class I, Zone 1 Hazardous (Classified) Locations. The Remote version is rated as Explosionproof Class I, Division 1, Groups C & D; Dust-Ignitionproof for Class II & III, Division 1, Groups E-G and Class I, Zone 1, Group IIB Hazardous (Classified) Locations with connections to a 700 Series sensor that is Intrinsically Safe for Class I, II & III, Groups A-G and Class I, Zone 1 Hazardous (Classified) Locations.

3.3.2 FM Canada Approvals - Install per 420-0004-412-CD

The Universal IV Level Transmitter is rated as Intrinsically Safe for Class I, II and III, Groups A-G and Class I, Zone 0, Group IIC, in accordance with drawing 420-0004-412-CD; Nonincendive Class I, Division 2, Groups A-D Hazardous Locations.

Furthermore, the Integral version is rated as Explosionproof for Class I, Division 1, Groups C & D; Dust Ignitionproof for Class II & III, Division 1, Groups E-G and Class I, Zone 1, Group IIB Hazardous Locations with an integral sensor that is Intrinsically Safe for Class I, II & III, Groups A-G and Class I, Zone 1 Hazardous Locations. The Remote version is rated as Explosionproof Class I, Division 1, Groups C & D; Dust-Ignitionproof for Class II & III, Division 1, Groups E-G and Class I, Zone 1, Group IIB Hazardous Locations with connections to a 700 Series sensor that is Intrinsically Safe for Class I, II & III, Groups A-G and Class I, Zone 1 Hazardous Locations.

3.3 Standards and Approvals (Continued)

3.3.3 ATEX Approvals - Install per 420-0004-424-CD

Universal IV Level Transmitter – Integral

II 1 G Ex ia IIC T4 Ga $-40^{\circ}\text{C} \leq T_{amb} \leq +75^{\circ}\text{C}$; IP66 (For models U**103**00-**-*)

II 2 G Ex d ia IIB T4 Gb $-40^{\circ}\text{C} \leq T_{amb} \leq +75^{\circ}\text{C}$; IP66 (For models U**104**00-**-*)

II 2 D Ex tb ia IIIC Db T90°C $-40^{\circ}\text{C} \leq T_{amb} \leq +75^{\circ}\text{C}$; IP66 (For models U**104**00-**-*)

Universal IV Level Transmitter – Remote (excluding models U**10***00-**-*)

II 1 G Ex ia IIC T4 $-40^{\circ}\text{C} \leq T_{amb} \leq +75^{\circ}\text{C}$; IP66 (For models U**103***0-**-*)

II 2 (1) G Ex d [ia] IIB T4 $-40^{\circ}\text{C} \leq T_{amb} \leq +75^{\circ}\text{C}$; IP66 (For models U**104***0-**-*)

II 2 (1) D Ex tb [ia] IIIC T90°C $-40^{\circ}\text{C} \leq T_{amb} \leq +75^{\circ}\text{C}$; IP66 (For models U**10****0-**-*)

700-*, Universal IV Sensors

II 1 G Ex ia IIC T2...T5 Ga $-40^{\circ}\text{C} \leq T_{amb} \leq +75^{\circ}\text{C}$

II 1 D Ex ia IIIC T300°C...T90°C Da $-40^{\circ}\text{C} \leq T_{amb} \leq +75^{\circ}\text{C}$

3.3.4 IECEx Approvals - Install per 420-0004-424-CD

Integral:

Ex ia IIC T4 Ga; Ex d ia IIB T4 Gb; Ex tb ia IIIC T90°C Db;
 $-40^{\circ}\text{C} \leq T_a \leq +75^{\circ}\text{C}$; IP66

Input Voltage: 13-30Vdc; 1W

Remote:

Ex ia IIC T4 Ga; Ex tb [ia] IIIC T90°C Db; Ex d [ia] IIB T4 Gb;
 Ex tb [ia] IIIC T90°C Db; $-40^{\circ}\text{C} \leq T_a \leq +75^{\circ}\text{C}$; IP66

Input Voltage: 13-30Vdc; 1W

Remote Sensor:

Ex ia IIC T5 ... T2 Ga; Ex ia IIIC T90°C ... T300°C Da; $-40^{\circ}\text{C} \leq T_a \leq +75^{\circ}\text{C}$; IP66



205 Keith Valley Road, Horsham, PA 19044
U.S. and Canada: 1-800-553-9092
24-Hour Service: 1-800-527-6297
International: +1 215-674-1234
Fax: +1 215-674-2731
E-mail: drexelbrook.info@ametek.com
Website: www.drexelbrook.com